

Step by Step

IMPLEMENTATION GUIDELINES

for Urban Water Point/ Stand Post

DRAFT

URBAN

February 2007

CONTACT

WaterAid Bangladesh

House 97/B, Road 25, Block-A
Banani, Dhaka, 1213

Bangladesh

Tel. ++880 (0)2 881 5757, 881 8521

Tel/Fax: ++880 (0)2 881 8521

Email: info@wateraidbd.org

Web: www.wateraid.org

Table of Content

Glossary	iv
1. Introduction.....	6
1.1 Purpose and Use of this Guideline	6
2. Steps for Implementation of Water Point/ Stand Post.....	7
Step 1: Needs Identification.....	7
Step 2: Application for Water Supply Facilities	8
Step 3: Site Verification for Water Supply Facilities.....	8
Step 4: Selection of Appropriate Model of Water Point/ Stand Post.....	9
Step 4.1: Selection of Appropriate Design / Re-designing of Context-specific Water Point/ Stand Post	9
Step 4.2: Approval of Design, Drawing and Cost-estimate for Context-specific Water Point / Stand Post.....	9
Step 5: Approval from concern Partner Organization.....	10
Step 6: Approval from utility department.....	10
Step 7: Calculation of Cost Recovery.....	9
Step 8: Formation and orientation of Management Committee & Purchase Committee	10
Step 9: Caretaker Selection.....	11
Step 10: Construction of Water Point/ Stand Post	11
10.1 Procurement of materials:.....	11
10.2 Selection of Mason and Labourers	11
10.3 Construction.....	11
10.4 Selection of Skilled Mistree.....	12
10.5 Connection to WASA main	12
Step 11: Statement of Expenditure	12
Step 12: Water Quality Test.....	13
Step 13: Completion Report	14
Step 14: Adjustment of Advance payment and Final Payment to the Mason Leader	14
Step 15: Orientation to the Caretakers' and Management Committee.....	14
Step 16: Handing Over	14
Step 17: Cost Recovery.....	15
Step 18: Monitoring & Follow-up.....	15
Step 19: Documentation.....	15
Annex-1	16
Annex-2	19
Annex-3	20
Annex-4	22
Annex-5	23
Annex-6	24
Annex-7	25
Annex-8	26
Annex 9.....	28

Abbreviations

ASEH	: Advancing Sustainable Environmental Health
CAP	: Community Action Plan
CBO	: Community Based Organization
CC	: City Corporation
CSA	: Community Situation Analysis
DFID	: Department for International Development
DPHE	: Department of Public Health Engineering
F	: Functional
GoB	: Government of Bangladesh
HH	: Household
HTW	: Hand tube well
LGI	: Local Government Institution
lpcd	: litre per capita per day
NF	: Non-functional
NGO	: Non-government Organization
O&M	: Operation and Maintenance
PE	: Project Engineer
PF	: Partially Functional
PO	: Partner Organization
Rehab	: Rehabilitation
USP	: Urban Stand Post
UWP	: Urban Water Point
Unicef	: United Nations Children Emergency Fund
WAB	: WaterAid Bangladesh
WatSan	: Water and Sanitation
WHO	: World Health Organization
WQ	: Water Quality
WS	: Water Supply
WSS	: Water Supply & Sanitation
WASA	: Water Supply & Sewerage Authority

Glossary

1. Urban Water Point (UWP)

Water points are set-up with an underground/ over-ground reservoir connected to the WASA mains; hand pump heads are mounted on top of the reservoir, so that water could be extracted via mechanical pressure. There is a platform above or around the reservoir for water collection, washing & bathing.

Water points are applicable for urban areas where centrally managed water supply systems exist. In particular, this technology is applicable for Dhaka, Chittagong, & Khulna city and Narayanganj Pourashava areas.

Reservoirs made of 10 inch brick having strong plastering are in practice. But Ferro cement reservoir is recommended, where possible, for the following reasons:

- Less risk of contamination
- Reduced cost comparing brick made reservoir

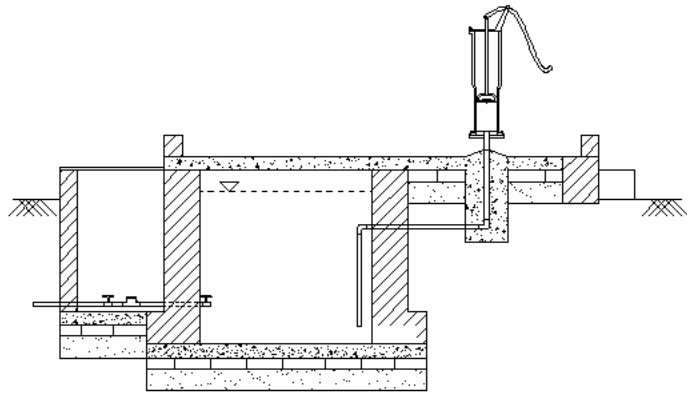

Models	Description	Approx. Cost (Taka)	Target HHS
WP- 1	reservoir-Brick made, 3200 l, Washing/ bathing platform, TWs, meter pit, meter (1" dia water supply connection)	62,000	40 - 60
WP- 2	Reservoir- Brick made, 5000 l, pipe networking, 6- washing/ bathing platform, TWs, meter pit, meter (1.5" dia water supply connection)	142,000	90 - 120
WP- 3	reservoir-ferro-cement, 3600 l, Washing/ bathing platform, TWs, meter pit, meter (1" dia water supply connection)	56,500	40 - 60
WP- 4	Reservoir- ferro-cement, 5000 l, pipe networking, 6-washing/ bathing platform, TWs, meter pit, meter (1.5" dia water supply connection)	137,000	90 - 120
WP- 5	reservoir- Brick made, 2200 l, Washing/ bathing platform, TWs, meter pit, meter (1" dia water supply connection)	56,500	25 to 40

2. Urban Stand Post (USP)

Stand Posts are directly connected to the WASA mains; a tap/ hand pump is connected with the WASA mains through 1 inch dia service pipe, so that water could be extracted through gravity or mechanical pressure. There is a platform with the tap stand for water collection, washing & bathing.

This option is also applicable for urban areas where centrally managed supply water exists.

Stand Post option could be selected instead of Water point when:

- i) the water supply is regular (continuous supply)
- ii) there is sufficient water pressure i.e. at the height of 3ft above the ground
- iii) comparatively less HHs are available to cover

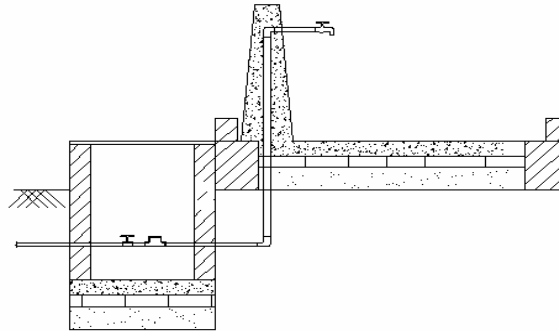

Models	Description	Approx. Cost (Taka)	Target HHs
Water Supply through stand post (USP)	Platform, TW/ tap stand, meter pit & meter (1" dia water supply connection)	31,500	15

3. Access:

Access to be defined as presences of safe water options within 50 meter (150 feet) distance from the HHs with minimum required quantity of water per capita is available. 23 lpcd considered as the minimum water requirement per capita per day [20 lpcd for drinking and cooking purposes + 3 lpcd for sanitation and hygiene purposes].

4. Functional

Water point/ Stand Post which meets the following criteria -

- a. Produce adequate quantity of water [23 lpcd] having acceptable quality round the year.
- b. All necessary components (service line/ meter pit/ meter/ reservoir/ hand pump etc.) are in good condition.
- c. Clean, effective and good quality platform is available.
- d. Effective waste water disposal pit or drainage system is available.

5. Partially Functional

- a. Water point/ Stand post which meets partially of the criteria mentioned in **4a**.
- b. Any of the necessary components (service line/ meter pit/ meter/ reservoir/platform/drainage system, etc.) are not functioning properly. These types of problems may be reactivated or can be made functional with minor repairing.

6. Non-Functional

- e. Water point/ Stand post which is completely out of order especially which does not meet the criteria mentioned in **4a**.

1. Introduction

WaterAid is an international non government organization dedicated exclusively to the provision of safe domestic water, sanitation and hygiene education to the world's poorest people. WaterAid has been working in Bangladesh since 1986 through local partner organizations (NGOs) to improve hygiene behavior and access to water and sanitation services for poor communities giving emphasis on demonstration of innovative approaches, participatory methods, gender and vulnerable groups, hygiene promotion, monitoring and evaluation and sustainability.

Advancing Sustainable Environmental Health (ASEH) is a DFID supported major project of WaterAid Bangladesh (WAB) for hygiene promotion, environmental sanitation and water supply. It is being implemented in partnerships with local rural and urban NGO partners. The project started in July 2003 and will be end up in March 2009.

One of the major objectives of ASEH is to ensure access to, and use of safe and adequate water and environmental sanitation facilities; and improvement in hygiene behavior in the target communities in rural areas and urban slums. WaterAid is promoting community managed safe water supply and sanitation facilities for urban and rural poor in challenging geographical, socioeconomic and technical contexts in Bangladesh.

WAB and Partner Organizations have been offering a range of water supply technology options to address the needs of communities located at different geo-physical context. Under urban context, the following water supply options are usually offered -

- Urban Water Point (UWP)
- Urban Stand Post (USP)
- Different types of tube wells (shallow, deep- set, deep)

This Guideline is particularly dealing with 'Water Point' and 'Stand post'. Definitions of these Water Point and Stand Post are given in the glossary. Technical details are given in **Annex 9**.

1.1 Purpose and Use of this Guideline

This Guidelines has been prepared based on the **available Guidelines of WaterAid Bangladesh and Partner Organizations** and gathering experience over the last two years of implementation under ASEH and previous experience of pre- ASEH programme to meet the following purposes:

- The Guideline has been prepared as a tool to keep standard procedures for construction of different models of Water Point and Stand Post under the programme of WaterAid Bangladesh uniformly by all urban Partner Organizations.
- It was attempted to reflect WaterAid's policies as well as National Policies through the Guidelines in an operational manner and mainstreaming the policies.
- The Guidelines will be used as a Handbook for the frontline staff as well as professionals.
- The Guidelines will ensure involvement of community, LGIs, Utility departments and other concerned stakeholders as relevant through promotion of transparent, accountable, gender sensitive and pro-poor implementation of water supply facilities.
- The Guidelines will guide the Partner Organizations to implement the constructions with a certain level of flexibility allowing addressing local context in consultation and approval from WAB, if essential.

2. Steps for Implementation of Water Point/ Stand Post

The following steps should be adopted for implementation of Water Point/ Stand Post.

Step 1: Need Identification

In order to proceed for construction of a Water Point/ Stand Post, the following activities have to be undertaken as a part of needs identification:

- **Community Situation Analysis (CSA):** CSA must be conducted in a cluster or slum with facilitation by the respective frontline staff of Partner Organization following the CSA guidelines (pls. see the Guidelines on Community Situation Analyses).
- The status of existing water supply facilities, besides other relevant information of the particular cluster/community may be documented during CSA preferably using the format **WAB-2006/Prog-001**. The cluster/community identification should be marked by writing a number or note on top right corner of the same format).
- The summary information of water supply situation in the community obtained from the overall situation analysis may be presented similar to the format **WAB-2006/Prog-003**.
- Wellbeing ranking of the households in the cluster or slum must be determined during CSA.
- **Community Based Organization (CBO) Formation:** The cluster or slum must have a Community Based Organization (CBO) responsible for implementing the CAP.
- The frontline staff will assist the community to prepare the CAP and ensure that the policies of WAB are reflected. Preference must be given to poor HHs and HHs of unserved and underserved pockets.
- The CAP including proposed water options has to be carefully reviewed by respective frontline staff of Partner Organizations considering ASEH policy principles and endorsed by the CBO.
- **Community Action Plan (CAP):** The CAP should be prepared including required number of new or rehabilitation water supply facilities mentioning their types, number of users, timeframe for construction, responsibilities and budget as follows (**CAP: Construction/ Installation of water supply options**).
- During preparation of the CAP, respective frontline staff will assist to identify type and number of required water supply facilities in line with relevant WAB policies (no. of hhs/ different type of Water Point/ Stand Post model, please see glossary for details).

CAP: Construction/ Installation of Water Supply Options

Preferred Option	Preferred Model*	No. of WS options		No. of HHs covered		Time frame	Responsibility	Budget	Remarks
		New	Rehab	New	Rehab				
Water Point									
Stand Post									
Tube well									
Others									
Total:									

**Finally the suitable Model will be determined by Engineer of partner on the basis of technical parameters.*

Step 2: Application for Water Supply Facilities

Based on the priority determined in CAP, respective frontline staff along with CBO members will have meeting(s) with the users to determine list of applicant households, their occupations, category of their wellbeing ranking, number of users etc. and also select their preferred **Water Supply** option.

The respective frontline staff must explain the conditions of applying for a particular option (e.g., estimated total cost, users' contribution, cost-recovery mechanism, formation of Management Committee & Purchase Committee, roles & responsibilities of the Committees, caretakers' selection process, caretakers' responsibilities, use and O&M of the facilities etc.) to the applicants in detail.

Upon discussing the mentioned issues, the applicant households will fill-in an Application Form (**Annex-1**) for a particular **Water Supply** option.

Main Conditions for Applying:

- At least minimum required number of households should apply together for a particular Water point/ Stand Post considering the 'number of households vs model'
- Applicant households must have a nearby reliable WASA supply main (max. 500 m) with adequate water pressure to produce adequate water.
- An agreed common and convenient place should be identified (with reference to three permanent objects) for construction of the chosen Water point/ Stand Post.
- Upon approval of the application, applicant households must share the contribution money as per ASEH Cost Sharing Strategy
- The applicant households must select one male and one female from the applicant households/ agree to select the members from the Management Committee as caretakers for the Water point/ Stand Post.

The respective frontline staff should assist the applicants to select site for construction of proposed Water point/ Stand Post properly considering the **site selection criteria** in consultation with both male and female members from the applicant households.

The frontline staff must ensure that signatures are obtained in the Application Form from both male and female members from the applicant households.

The filled-in Application Form will be recommended / countersigned by the respective cluster or slum CBO and then submitted to the Partner Organization.

Site selection criteria:

- Applicable in densely populated slum areas.
- Have a nearby reliable WASA supply main (max. 500 m) with adequate water pressure
- Usual annual flood level should be considered.
- Avoid the site which is very near to any water body/ ditch/ drain/ latrine
- Provision of easy access by potential users.
- A common agreed place.
- ASEH policy principles to be generally followed for site selection.

Step 3: Site Verification for Water Supply Facilities

The frontline staff should forward the Application Form to respective Supervisor of the Partner Organization.

The Supervisory staff and/ or Engineer will visit the site for verification. During site verification the Supervisory staff/ Engineer will critically observe the following aspects:

- Reliability of information as mentioned in the Application Form.
- Social and technical feasibility of the proposed site for the particular water supply option.

Comments / recommendations should be made by the Supervisory staff/ Engineer on the Site Verification Form.

Step 4: Selection of Appropriate Model of Water Point/ Stand Post

Water Point/ Stand Post will be chosen by the community in consultation with the POs staff but, a particular **Model** of Water Point should be recommended by Engineer considering hydro-geological situation of the area concern and number of users.

Step 4.1: Selection of Appropriate Design / Re-designing of Context-specific Water Point/ Stand Post

The Engineer will recommend a particular Model for the selected Water Point/ Stand Post option.

If any context specific modification is required, Engineer will write details in the comment/ recommendation box including the possible closest Model.

Accordingly, Engineer will re-design a context-specific Water Point/ Stand Post choosing the possible closest Model from the available standard designs (say, UWP-1). During re-designing, s/he will consider similar design parameters of the closest chosen option and prepare design, drawing and estimate for that particular context-specific option.

Some basic design considerations:

- Need to ensure minimum water consumption rate 20 liter/capita / day and 2/3 li for sanitation purposes
- Annual Flood level should be considered during construction (Platform and reservoir)
- Platform size should not be less than 5'x 5'
- Proper drainage system to dispose waste water from the platform

Step 4.2: Approval of Design, Drawing and Cost-estimate for Context-specific Water Point / Stand Post

After reviewing the design, drawing and cost estimate of the context specific water supply option at Partner Organization level the same will be forwarded to WAB office for approval.

After reviewing (desk review and / or site visit), WAB will approve/ suggest necessary modifications.

In case, any modification is suggested by WAB, the respective Partner Organization needs to re-submit the same to WAB for approval after accommodating the suggested modifications.

Before approving, WAB will put the Water Supply Code (say, **UWP- 1-NGO-2**). Then original copy of the approved design and estimate will be sent to respective Partner Organization while a photocopy of the same will be kept at WAB office for future reference.

Step 5: Calculation of Cost Recovery

The concerned frontline staff as per the ASEH Cost Sharing and Recovery Strategy will determine the amount of capital cost to be shared by individual applicant household, the number of installments and amount in each installment. The frequency of installment should be monthly and with a maximum of 24 months.

The applicant households will be informed by the respective Partner Organization's staff about the estimated total installation cost of option, total amount to be contributed, number of installments, amount in each installment and project subsidy. The applicant households should also be aware about the reason of different amount of contribution by the Applicant households for the same option.

Step 6: Approval from concern Partner Organization

- After the site is verified by the Engineer and **Model** is suggested or **re-designed Model** is approved by WAB, the Application along with Site Verification Form, estimated cost and cost contribution by the community will be placed to Executive Director/ competent authority of Partner Organization for approval.
- Once the Application Form is approved, a simple approval letter (**Annex-2**) will be issued by the Executive Director or approving authority of Partner Organization to the President, CBO/ Management Committee/ Representative of the Applicant Households of that particular option to acknowledge their demand and proceed for next step.

Step 7: Approval from utility department

- Partner Organization will submit an application to the approving authority of DWASA for getting approval of a service connection for the selected option. This forwarding letter will include location and location map.
- The competent approving authority will review the application, may go for site verification, and will give the conditional (security money, meter & meter pit, reservoir, billing system, etc.) approval.
- After getting the approval from WASA, the document to be submitted to the zonal office of WASA for issuing demand note and finally to get the connection permission. A sample of the approval letter is attached in the **Annex-3**
- In case of getting road cutting permission from City Corporation (CC), an application will be submitted along with forwarding letter and location map to the concerned office of City Corporation. Road cutting fee, prescribed by City Corporation, will be deposited for getting permission.

In either case (step 5 & 6), if the Application is rejected, the applicant households will be informed with reasons for not being accepted by the authority. (say, due to not meeting the criteria).

Step 8: Formation and orientation of Management Committee & Purchase Committee

A **Management Committee** has to be formed for each Water Point/ Stand Post option upon consensus of the users with representation from both male & female from different categories of the user households. The roles and responsibilities of Management Committee includes-

- facilitation for collection of money for cost-recovery and O&M,
- maintaining registers,
- selection of caretakers,
- ensuring regular payment of WASA bills
- monitoring of water quality,
- cleaning of reservoir, etc.

A **Purchase Committee** is to be formed only for period of construction with two representatives (one male and one female) from the applicant households nominated by the Management Committee and two from Partner Organization preferably one frontline staff and the Engineer. The Purchase Committee will be responsible for all the activities related to construction of Water Point/ Stand Post which include purchase of construction materials, quality control, engagement of mason and labourer, payment to mason and labourer, accounts management etc.

The members holding the key positions (President, Secretary) in the concerned CBO and the Management Committee should not be a member of the Purchase Committee.

The respective frontline/ supervisory staff should provides an Orientation to Management Committee and Purchase Committee including caretakers (optional) regarding their roles and responsibilities before the construction starts.

Step 9: Caretaker Selection

A total of two (one male and one female) caretakers to be selected for each of the Water Point/ Stand post as mentioned in the application form. The members of Management Committees may also take over the responsibilities of caretakers by rotation instead of engaging fixed caretaker. But in this case the name and period for which the person is assigned will be specified.

Caretaker selection criteria:

- Caretakers must be selected from the users/ local community.
- Management Committee can engage full/part time caretakers as per need.
- Members of Management Committees may take the responsibilities of Caretakers by rotation, if agreed by community and Partner Organization.
- Selected Caretakers should be capable, hard working and committed.
- Caretakers must be willing to receive training and subsequently continue for regular O&M of the facility.
- Management Committee can fix remuneration for full/part time engaged Caretakers.

Step 10: Construction of Water Point/ Stand Post

10.1 Procurement of materials:

The **Purchase Committee** is primarily responsible for purchasing all material required for the Water Point/ Stand Post as per approved design and cost estimate following the procedures of the partner organization. The respective Engineer of Partner Organization will be responsible for ensuring the quality of materials procured.

10.2 Selection of Mason and Labourers

The Purchase Committee will engage the individual masons and labourers for construction of the Water Point/ Stand Post. The Purchase Committee may also, as alternative, identify/ enlist mason groups/ mason leader and select one mason group on the basis of experience of doing similar construction. In case the Purchase Committee engage the mason group a contract (**Annex-4**) between the Meson leader and the Purchase committee/ Management Committee will be signed. Preference will be given to the locally available masons, labourers or mason groups.

Each Partner Organization will develop and adopt a systematic and transparent procedure for selection of masons.

10.3 Construction

The Water Point/ Stand Post will be constructed by the assigned local mason group as per the contract agreement and approved design and cost estimate.

During construction quality assurance will be done by the Partner Organization's staff, preferably by Engineer and the following issues to be taken into considerations:

- Construction is done at the site approved earlier.
- Construction layout is done properly
- The materials purchased are properly stored and used.
- Construction of reservoir & platform including drainage will be followed as per approved design and specification.
- Curing is done properly.

Upon completion of construction, **ASEH marking** (sample is given in **Annex-5**) should be made on the place which is visible to all. ASEH marking should contain prescribed WAB standard containing identification mark and other relevant information.

10.4 Hiring / engaging Skilled Mistree

The Purchase Committee will engage the individual skilled mistree and labourers for laying pipe line from the main line to the Water Point/ Stand Post. The Purchase Committee may also, as alternative, identify/ enlist /select skilled mistree on the basis of experience of doing similar work. In case the Purchase Committee engage the skilled mistree a contract (**Annex-6**) between the skilled mistree and the Purchase committee/ Management Committee will be signed.

Selection of the skilled mistree will be based on the following criteria-

- Have experience on WASA water line connection
- Direct employee of WASA

10.5 Connection to WASA main

The Water line connection from WASA service line and pipe layout of the Water Point/ Stand Post will be done by the assigned skilled mistree.

The quality assurance will be done by the Partner Organization's staff, preferably by Engineer and the following issues to be taken into considerations:

- The original copy of WASA & Zone permission letters will at the site with the PO staff
- Tidiness of the site should be maintained
- Mistree should be fully equipped
- Connection from the WASA supply main is done properly
- GI pipes to be used for connection
- Pipe layout is done properly.
- WASA procedures to be followed.

Step 11: Statement of Expenditure

The Purchase Committee will preserve all vouchers and maintain accounts. The Purchase Committee will time to time report to the Management Committee regarding the progress of work and status of expenditure. After completion of construction, the Purchase Committee will prepare a **Statement of Expenditure (Register Book)** along with all supporting cash memos/ bills countersigned preferably by all members from that Committee.

A meeting will be arranged with Management Committee and applicant groups where the **Statement of Expenditure** will be presented by the Purchase Committee for countersigning. The

date and time of the meeting will be informed to the respective Management Committee and users well ahead to ensure their participation.

Upon presentation of Statement of Expenditure by the Purchase Committee and subsequent countersigning by the Management Committee, this should be forwarded to the respective Partner Organization for review and approval.

Step 12: Water Quality Test

12.1 Installation testing

Once the construction is completed and connection from WASA main is done, water quality parameters to be tested as per '**Water Quality Standard & Testing Policy**'.

Parameter	WAB acceptable limit	Method & frequency
Environmental inspection and Sanitary inspection	WAB- prescribed SI form for UWP/ USP	<u>Environmental inspection by WAB partners before proceeding with installation to identify possible WQ risks (eg proximity to latrines, flooding risk etc)</u> <u>Frequent community level sanitary inspection, as part of routine O&M</u> Sanitary inspection form to be completed by WAB Partner, if a problem identified by the community and during collection of samples for thermotolerant (faecal) coliform test.
Thermo-tolerant (faecal) Coliform	<u>0 - 10 fc/ 100ml</u>	<u>Testing should be done with the Delagua field test kit.</u> <u>Once reliability of a scheme is established the water should be tested on at least a quarterly basis.</u> <u>Frequent monitoring of thromotolerant (faecal) coliform will be necessary if a problem identified during community or PO sanitary inspection</u>
Turbidity	10 NTU	<u>Testing should be done with the Delagua field test kit.</u> <u>Once reliability of a scheme is established the water should be tested on at least a quarterly basis.</u>
Free and total chlorine	Minimum free 0.2mg/l Maximum free 5mg/l Total >0.2mg/	<u>Supplies from urban water points should be tested at the same time as bacteriological and turbidity testing using simple field test kit.</u>

If the water quality appears to have bacteriological contamination, the following actions to be taken:

- Check any leakage in pipe fittings and joints
- Check the connection of the conduit and meter.
- Check whether any leakage in the reservoir or reservoir is not cleaned with bleaching after construction
- Check whether reservoir is flooded by water logging, etc

12.2 Re-testing/ Monitoring Testing

The retesting applies to all WAB programme funded and Non-WAB programme funded Water Point/ Stand Post. 100% Water Point/ Stand post should tested on Quarterly Basis. (For details please see **Water Quality Standard & Testing Policy**).

12.3 Record keeping

Partner Organizations must keep records of all water quality tests. WAB prescribed form (SI form and Bacteriological test form) should be completed in the field and kept for each Water Point/ Stand Post. Information of SI and water quality test should include its unique identification number and geo-reference in a systematic manner.

Step 13: Completion Report

A '**Completion Report**' containing detail information including type & model, location, start & completion date of construction and other technical information of the Water Point/ Stand post will be prepared by the Partner Organizations as per the attached format (**Annex 7**) which will be acknowledged by the users.

The '**Completion Report**' must be kept at Partner Organization's Office as a proof of completion of task and acceptance by respective users.

Step 14: Adjustment of Advance payment and Final Payment to the Mason Leader

After reviewing the **Completion report** and cash memos/ bills, **Statement of Expenditure** will be approved by the competent authority of PO. Upon approval of the Statement of Expenditure necessary adjustment of the advance to respective staff against the facility will be made. The Purchase Committee may pay full payment to the masons as per their actual work before approval of the Statement of Expenditure if justified.

Step 15: Orientation to the Caretakers' and Management Committee

The Partner Organization will organize an orientation session to the enlisted caretakers and the Management Committee about their roles and responsibilities and operation & maintenance, of the facilities. However, the frontline staff/ Trainer/ Engineer will be responsible for orientation session at site preferably within one week after completion of work.

In addition to this orientation session the Partner Organization may organize advanced training to the Caretakers on operation and maintenance afterwards.

Step 16: Handing Over

At the end of orientation session to the Caretakers and the Management Committee, a simple formal **Handing Over Ceremony** will be organized in the presence of Management Committee/ applicant households.

A '**Handing Over Note**' along with users acknowledge should be filled-in by Partner Organization's staff and to be acknowledged by the President, CBO on behalf of users/ Management Committee. (**Annex-8**).

During handing over, photocopy of 'Hanging Over Note' must be handed over to the **Management Committee** while original copy of the same will be kept at Partner Organization's Office as a record for handing over the facility to the respective users.

Step 17: Cost Recovery

As soon as the Water Point/ Stand Post is handed over and subsequently formally taken over by the users, cost recovery will be started.

The concerned frontline staff already fixed up (**Step-5**) the amount and number of installments applicable for each applicant household as per the **Cost Sharing and Recovery Strategy**.

The respective Management Committee will be responsible to collect the cost recovery money from applicant households and deposit the same to the designated frontline staff of the Partner Organization regularly. The respective frontline staff will deposit the cost recovery money to Partner Organization's office within maximum of one week time after collection from Management Committee. The Partner Organization's office will deposit the money to Bank within maximum of one week (Please see the **Financial Guidelines for Partner Organizations**).

In case the recovered cost sharing amount managed by the community and keep with them instead of Partner NGO, the community will collect and deposit as per the policy/ guidelines to be finalized.

A register should be introduced mentioning names and amount of cost recovery for each of the user households. This should be updated at every month. Proper documentation should be kept at register to ensure transparency of this process.

Step 18: Monitoring & Follow-up

After construction, the staff of Partner Organization will regularly monitor the functionality, use and Water Quality for at least three months after the handing over of the facility.

The following aspects should be considered during monitoring by Partner Organization's staff.

- Functionality of the Water Point/ Stand Post - Produce adequate quantity of water having acceptable quality round the year.
- Regular payment of WASA bills
- Regular cleaning of reservoir with bleaching powder
- Water logging around the reservoir and meter pit
- Cleanliness of surroundings
- Status of the all components of Water Point/ Stand Post
- User friendliness of the system
- caretakers role and responsibilities;
- Accessibility to all users.

Step 19: Documentation

The information related to Water Point/ Stand Post should be recorded in the slum-based Water Point/ Stand Post Register. It is expected that register will be made available to each Partner Organization.

Annex-1

..... (Name of Partner Organization)

Advancing Sustainable Environmental Health

Application Form for UWP/ USP

Model No: (after approval of design)

1. Application Sl. No: 2. UWP/ USP Code No: (After construction)

3. Date of Application: 4. Slum:

5. Ward: 6. City:

7. Proposed site for Water Point/ Stand Post

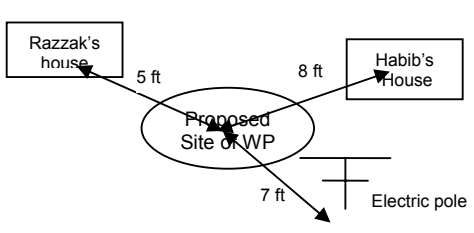
Cluster / CBO No:	<p style="text-align: center;">Sketch of the proposal site</p> 
Ownership pattern of Slum: (City Corporation/ Private/ Government agency (mention).....)	
Distance from nearest safe water source: (meter)	
Distance from WASA supply mains: (meter)	
Distance from nearest water body/ ditch/ latrines: (meter)	

8. Information of Applicant Households:

Sl. No	Name of Household Head		Occupation		Wellbeing Ranking	No. of HH member*				Signature	
	Female	Male	Female	Male		F	M	C	T	Female	Male
1											
2											
3											
4											
5											
6											
7											
8											
9											
10											
11											
12											
13											
14											
15											
16											

Sl. No	Name of Household Head		Occupation		Wellbeing Ranking	No. of HH member*				Signature	
	Female	Male	Female	Male		F	M	C	T	Female	Male
17											
18											
19											
20											
21											
22											
23											
24											
25											
26											
27											
28											
29											
30											
31											
32											
33											
34											
35											
36											
37											
38											
39											
40											

*M= Male; F=Female; C=Children; T=Total

Note: Age below 10 years will be considered as children

Proposed Caretakers*:

1. Caretaker's Name: Father / Spouse :

2. Caretaker's Name: Father / Spouse:.....

Alternative arrangement:

Name of the Representative, Applicant Households

Name of Frontline Staff, PO

Signature

Signature

Date: -----

Date: -----

Recommended by

Name of the President, CBO: -----

Signature: -----

Date: -----

9. Main Condition for Applying:

- At least minimum required number of households should apply together for a particular Water point/ Stand Post considering the 'number of households vs model'
- Applicant households must have a nearby reliable WASA supply main (max. 500 m) with adequate water pressure to produce adequate water.
- An agreed common and convenient place should be identified (with reference to three permanent objects) for the construction of the chosen Water point/ Stand Post .
- Upon approval of the application, the applicant households must share the contribution money as per ASEH Cost Sharing Strategy
- The applicant households must select one male and one female from the applicant households/ agree to select the members from the Management Committee as caretakers for the Water point/ Stand Post.

* Management Committee can engage full/part time caretakers as per need and fix remuneration for them.
 * Members of Management Committee may take the responsibilities of Caretakers by rotation, if agreed by community and Partner organization.

For Official Use Only

10. Site Verification Form for UWP / USP

Model No: (after approval of design)

Supervisory Staff and/or Engineer of Partner Organization will fill-up the following box after visiting the site and verifying the information in the Application Form:

Comments/ recommendations by Supervisory Staff and/or Project Engineer:	
Name & Designation:	Name & Designation:
Date & Signature:	Date & Signature:
Available standard designs of UWP / USP can be constructed: Yes <input type="checkbox"/> No <input type="checkbox"/>	
If yes, Model recommended by Engineer:	
If no, please write detail in comments including possible closest Model: Comments/ recommendations by Engineer	
Name & Designation:	
Date & Signature:	

Site Approval:

Approved: <input type="checkbox"/>	Not Approved: <input type="checkbox"/>	Name: Executive Director/ Competent Authority of Partner Organization
Date & Signature		

Annex-2

..... (Name of Partner Organization)

Advancing Sustainable Environmental Health

Approval Letter for UWP / USP
Model No: (after approval of design)

Date:

To: _____

(President, CBO/ Management Committee/ Representative of applicant households)

Designation: _____

Spouse/Father's Name: _____

Cluster/ CBO No.: _____

Slum Name: _____

Ward No: _____

City: _____

.....(Partner Organization) is hereby pleased to inform you that the application for a **Water Point/ Stand Post** submitted by you and the other applicants has been approved.

The total estimated cost of the Water Point / Stand post is Tk..... You are requested to deposit a total amount of Tk..... at monthly installments inmonths as the contribution money from the applicant households according to the ASEH Cost Recovery and Sharing Strategy to the assigned staff by Partner Organization

The site mentioned in the application form can not be changed without prior approval from the concerned approving authority.

Prepared by

Signature

(Project Manager/ Coordinator of PO)

Executive Director/ Approving Authority:
Partner Organization:

Date: _____

Date: _____



ঢাকা পানি সরবরাহ ও পয়ঃ নিষ্কাশন কর্তৃপক্ষ

বাণিজ্যিক ব্যবস্থাপকের দপ্তর

ওয়ারসা ভবন (৮ম তলা)

৯৮, কাজী নজরুল ইসলাম এভিনিউ, ঢাকা।

স্মারক নং- ২৪, নি/সম/০৪/১০

তারিখঃ- ১৫/০৪/১১

অখিল চন্দ্র দাস

উপ-সম্বন্ধকারী (বাস্তবায়ন)

পানি ও পয়ঃ নিষ্কাশন প্রকল্প

দুঃস্থ স্বাস্থ্য কেন্দ্র(ডিএসকে)

১২/৩, পল্লবী, মিরপুর।

বিষয়ঃ- মিরপুর এলাকায় ঢাকা ওয়ারসার অঞ্চল-৪ এর আওতাধীন গাবতলী সিটি কলোনী বসতিতে মোট ৩(তিন)টি ১.৫"(দেড় ইঞ্চি) ব্যাসের পানির সংযোগ প্রদানের অনুমতি প্রসঙ্গে।

সূত্রঃ- স্মারক-DSK/ASEH-DWASA Component, তাং-২৮/০২/০৬ ই

উপরোক্ত বিষয়ে ও সূত্রের প্রতী আপনার দৃষ্টি আকর্ষণ করিতেছি। বিষয়ে বর্ণিত বসতিতে ১.৫" ব্যাসের পানি সংযোগ প্রদানের বিষয়টি পর্যালোচনা করা হইয়াছে। বর্ণিত বসতিতে নিম্নলিখিত শর্তের আলোকে পানি সংযোগ প্রদানের বিষয়ে কর্তৃপক্ষ সম্মত হইয়াছেন।

শর্তসমূহঃ

- ১। ঢাকা ওয়ারসার সংযোগ বিধি মানিয়া চলিতে হইবে।
- ২। প্রতিটি পানি সংযোগের জন্য ২,০০০/- (দুই হাজার টাকা) করিয়া ঢাকা ওয়ারসার অনুকূলে জামানত হিসাবে জমা দিতে হইবে।
- ৩। পানির বিল ২,০০০/- (দুই হাজার) টাকার বেশী বাকী পড়িলে কোন প্রকার নোটিশ ব্যতিরেকেই পানি সংযোগ বিচ্ছিন্ন করা হইবে।
- ৪। ভিমান্ড নোটের প্রয়োজনীয় টাকা জমা এবং সংযোগের অনুমতিপত্র প্রাপ্তির পর জি আই পাইপ দ্বারা সংযোগ গ্রহন করিতে হইবে।
- ৫। নিজ খরচে মিটার চেম্বার নির্মাণ এবং নিরাপত্তা নিশ্চিত করিতে হইবে এবং জলাধার নির্মাণ করিতে হইবে।
- ৬। এই সকল সংযোগ হইতে পানি ব্যবসায়িক কর্মকাণ্ডে ব্যবহার করা যাইবে না।
- ৭। পানি ও পয়ঃ অতিক্রম পরিশোধের বিষয়ে এন,জি,ও প্রতিষ্ঠান সরাসরি দায়বদ্ধ থাকিবে এবং প্রতিমাসে অতিক্রম পরিশোধ করিবে।
- ৮। রাস্তার পার্শ্বে অবস্থিত বসতিতে সংযোগের অনুমতি প্রদানের পূর্বে রোড ওনিং এজেন্সি/জমির মালিকের নিকট হইতে নো-অবজেকশন সার্টিফিকেট দাখিল করিতে হইবে।
- ৯। বসতির লোকেশন ম্যাপ ও জলাধারের আকার ইত্যাদি দাখিল এবং ওয়ারসা কর্তৃক অনুমোদন হওয়ার পর সংযোগ গ্রহন করিতে হইবে।
- ১০। প্রয়োজনে ওয়ারসা কর্তৃপক্ষ বসতির পানির সংযোগ বন্ধ করিতে পারিবেন।
- ১১। পানির লাইন খাঁকা সাপেক্ষে সংযোগ গ্রহন করিতে হইবে।

উপরোক্ত শর্ত সাপেক্ষে আপনারা সংযোগ গ্রহনে সম্মত থাকিলে বর্ণিত সংযোগ সমূহের বিপরীতে টাকা জমা দেওয়ার জন্য অনুরোধ করা হইল।

(মোহাম্মদ নুরুল হুদা মিয়া)
বাণিজ্যিক ব্যবস্থাপক
ঢাকা ওয়ারসা।

অনুলিপিঃ-

- ১) প্রধান হিসাব রক্ষন কর্মকর্তা, ঢাকা ওয়ারসা।
- ২) নিবাহী প্রকৌশলী, মডুস জোন-৪, ঢাকা ওয়ারসা (কপি সংলগ্ন)।

নির্বাহী প্রকৌশলীর দপ্তর
মডস জোন-৪, ঢাকা ওয়াশা।

স্মারক নং- ৯৮-১১০৬/৪ সি,পি,নং- ৪৩৭৮ তারিখ- ৩১/৪/১৬

প্রতি,
জনাব/জনাবা মুহঃ মামুনুল হক (DSC)
স্বাস্থ্য (উপ-সহকারী) অফিস, মডস জোন-৪, ঢাকা ওয়াশা, এম এ মিডিয়াম সিলেক্টেড পুর্ব পল্লব,

বিষয়ঃ- উপরে উল্লেখিত আপনার হোল্ডিংয়ে আবাসিক বানিজ্যিক/সামাজিক পানি সংযোগ স্থাপনের অনুমতি পত্র।

আপনার স্মারক নং তারিখ অনুযায়ী সংযোগ ফি ব্যবদ প্রাথমিক চূড়ান্ত হিসাবে টাকা ২৪,২৫/- তারিখ ২৫/৫/১৬ জমা দেওয়ার প্রেক্ষিতে পরিদর্শনের রিপোর্ট অনুযায়ী ঢাকা ওয়াশা আন্ডার সবিও ওয়াশার মূল পানির লাইন হইতে নিম্নে বর্ণিত শর্ত সাপেক্ষে এবং দরখাস্তে উল্লেখিত শর্তানুযায়ী আপনাকে ২৫,০০০/- ব্যাস পানি সংযোগ মিটার যুক্ত / মিটার বিহীন অনুমোদন করিয়াছেন।

- আবেদনকারীর সংযোগ স্থাপন করার পূর্বে সংশ্লিষ্ট অফিস থেকে রাস্তা কাটার অনুমতি পত্র গ্রহণ করিতে হইবে।
- পানি অশুচ্য সোধ করার নিমিত্তে অলাকারে "শলকক" স্থাপন করিতে হইবে।
- মিটার হারানো কিংবা নষ্ট হওয়ার জন্য হোল্ডিংয়ের মাণিক বা পানি ভোগকারী সম্পূর্ণ দায়ী থাকিবেন। এক্ষেত্রে মাণিক কিংবা পানি ভোগকারী হইতে মিটারের মূল্য আদায় করা হইবে। যদি কখনো মিটার হারানো কিংবা নষ্ট হইয়া যায় তবে উহা প্রধান রাজস্ব কর্মকর্তা, কাওরান বাজার ওয়াশা স্ট্রবন, ৯৮ কাতী নতরগঞ্জ ইসলাম এডিনিউ, ঢাকা এর অফিসে জানাইতে হইবে।
- জি, আই, পাইপ দাগ সংযোগ নিতে হইবে।

মিটার নং ০০৬৪০
স্বাক্ষর মুহঃ মামুনুল হক

মুহঃ মামুনুল হক
(আ.ফ.ম.আর আডিক্স)
নির্বাহী প্রকৌশলী
মডস জোন-৪, ঢাকা ওয়াশা।
মুহঃ মামুনুল হক

স্মারক নং- তারিখ

- অবগতি ও প্রয়োজনীয় ব্যবস্থা গ্রহণের জন্য অনুলিপি প্রেরিত হইল।
- মেসার্স মিত্রাশীল নিম্নে বর্ণিত নিয়মানুযায়ী ভারপ্রাপ্ত প্রকৌশলীর নির্দেশ মোতাবেক সংযোগ স্থাপন করিতে হইবে।
 - সংযোগ সমাধা করার ২৪ (চব্বিশ) ঘণ্টার মধ্যে ব্যবহৃত মালামালের হিসাব ভারপ্রাপ্ত প্রকৌশলীর সিক্ট পেশ করিতে হইবে।
 - সংযোগ অনুমতি পত্র ইস্যু হওয়ার তারিখ হইতে ৩ (তিন) দিনের মধ্যে সংযোগ সমাধা করিতে হইবে।
 - সংযোগ সমাধা করার পর নর্ড কিংবা নাপা স্বায্যথ ভাবে ভরাট করিয়া ঠিক করিতে হইবে।
 - রাজস্ব কর্মকর্তা, রাজস্ব জোন-৪, ঢাকা ওয়াশা।
 - নির্বাহী প্রকৌশলী, মিটার বিভাগ, ঢাকা ওয়াশা। মিটার স্থাপন করার জন্য অনুরোধ করা হইল।
 - উপ-বিভাগীয় প্রকৌশলী/সহকারী প্রকৌশলী, জনাব মুহঃ মামুনুল হক মডস জোন-৪, ঢাকা ওয়াশা।
 - উপ-সহকারী প্রকৌশলী, জনাব মুহঃ মামুনুল হক মডস জোন-৪, ঢাকা ওয়াশা।
 - অফিস সহকারী (জুও), সি, এল, আই, সি, পি র কপি উপ-সহকারী প্রকৌশলীকে প্রদান করিতে হইবে।
 - অফিস কপি, জোন-৪, ঢাকা ওয়াশা।
 - সি, পি, গ্রহণের পর নির্দিষ্ট সময়ের মধ্যে গ্রাহক নিজ দায়িত্বে উপ-সহকারী প্রকৌশলীর উপস্থিতি তে রাস্তা কাটার অনুমতি দিয়া সংযোগ গ্রহণ করিতে হইবে।
 - ২৫,০০০/- ব্যাস হইতে সংযোগ গ্রহণ করিতে হইবে।

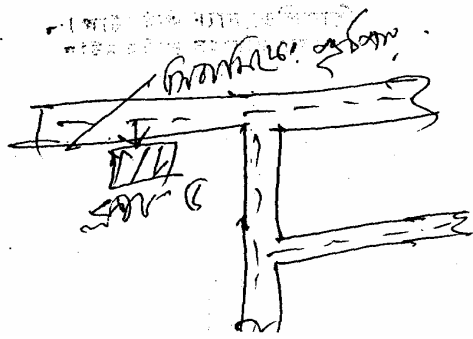

নির্বাহী প্রকৌশলী
মডস জোন-৪, ঢাকা ওয়াশা।

Annex-4

..... (Name of Partner Organization)

Advancing Sustainable Environmental Health

**Contract Agreement
with
Local Mason Leader**

Date:

To: Ms/Mr. _____

Detail address: _____

..... (The Partner Organization) is hereby pleased to inform you that you have been awarded for the construction of **Water Point/ Stand Post** .

This is to mention here that you are obliged to follow the terms & condition stated below –

1. Construction of mentioned Water Point/ Stand Post must be done according to the given design & drawing.
2. The construction must be completed within _____ days from signing contract including mobilization at site.
3. No advance payment will be made for this work.
4. Mason will be paid as below:
 - a. Total amount _____ tk for the entire construction.
 - b. Nature of payment will be _____, etc.
5. The Purchase Committee will provide all materials/ components according to the given design and specification.
6. The Purchase Committee will ensure safe custody of the materials procured
7. The final payment will be paid upon certification from community representative and Partner Organization's Engineer on satisfactory construction of facility.

Des.	Rate	Qty.	Man-days	Total
1. Mason leader	?00	X	XX	XXX
2. Skilled labor	?00	X	XX	XXX
3. Unskilled labor	?00	X	XX	XXX
4. Shuttering	???	X	XX	XXX
5. Others	???	X	XX	XXX
Total =				XXXX

Agreed by

(Name:)
Date: _____

Signature _____

Name _____
Community Representative, Purchase Committee
Date: _____

Signature: _____

Name _____
PO's Representative, Purchase Committee
Date: _____

Annex-5

Partner Organization: _____

Advancing Sustainable Environmental Health

ওয়াটারএইড বাংলাদেশ-এ্যাসে প্রকল্পের আওতাধীন নিরাপদ পানির ব্যবস্থাপনা এবং স্যানিটেশন অবকাঠামো সনাক্তকরণ

ওয়াটারএইড বাংলাদেশ স্থানীয় স্বচ্ছাসেবী সংস্থার সঙ্গে অংশীদারিত্বের মাধ্যমে প্রধান প্রধান শহরগুলির বস্তি এলাকা এবং গ্রামাঞ্চলের মানুষের জন্য নিরাপদ পানি, পয়ঃনিষ্কাশন ব্যবস্থাসহ সুন্দর পরিবেশ ও স্বাস্থ্যসম্মত জীবনমান উন্নয়নের লক্ষ্যে Advancing Sustainable Environmental Health (ASEH) প্রকল্পের বাস্তবায়ন করছে। ইতোমধ্যে বেশ কয়েকটি সহযোগী সংস্থা তাদের কর্ম এলাকার বিভিন্ন স্থানে নিরাপদ পানির ব্যবস্থাপনা ও স্যানিটেশন অবকাঠামো তৈরী করছে। ASEH প্রকল্পের আওতায় নির্মাণকৃত অবকাঠামোগুলোর সঠিক হিসাবের জন্য সনাক্তকরণ প্রয়োজন। এই লক্ষ্যে নিম্নে কিছু উদাহরণ দেয়া হলোঃ

নমুনা টিনের বা এ্যালুমিনিয়ামের শীটের তৈরী হলে ভাল হয়। ব্লকে যা থাকবে:

WAB-Name of PNGOs-ASEH

#Water Point Code-Completion month-Year

উদাহরণ:

WAB-VERC/DSK-ASEH
#00-124-Apr -2006

ব্লকের নমুনা:

WAB- DSK - ASEH
[] - [] 200.. []

msiké-mnṭhṃx ms̄vi big ṃbaṃi Z
_vKte e#K |

msiké-e#K G RvqMv duKv _vKte
ṭhLṽṭb l qṽUvi cṭqṭUi tKw, gṽṭmi
big Ges mij cṭdg©Zii i mgq
nṽZ ṽj LtZ nte| Kgcṭṽṽ Pvi
ṽṽRU tṽ Lvi gZ RvqMv duKv iṽLtZ
nte tKw bṽṽ Gi Rb̄ Ges ṽZb
ṽṽRU iṽLtZ nte gṽṭmi Rb̄ |

যদি ওয়াটার পয়েন্ট পুনঃ নির্মাণ হয় তাহলে ব্লক হবে নিম্নরূপ

WAB- DSK - ASEH
REH-[] - [] 200.. []

msiké-e#K G RvqMv duKv _vKte
ṭhLṽṭb l qṽUvi cṭqṭUi tKw, gṽṭmi
big Ges mij cṭdg©Zii i mgq
nṽZ ṽj LtZ nte| Kgcṭṽṽ Pvi
ṽṽRU tṽ Lvi gZ RvqMv duKv iṽLtZ
nte tKw bṽṽ Gi Rb̄ Ges ṽZb
ṽṽRU iṽLtZ nte gṽṭmi Rb̄ |

Annex-6

..... (Name of Partner Organization)

Advancing Sustainable Environmental Health

**Contract Agreement
with**

Skilled Mistree for water line connection & pipe layout

Date:

To: Ms/Mr. _____

Detail address: _____

..... (The Partner Organization) is hereby pleased to inform you that you have been awarded for the water line connection & pipe layout of **Water Point/ Stand Post** .

This is to mention here that you are obliged to follow the terms & condition stated below –

- 8. Water line connection from WASA service line and pipe layout must be done according to the Engineer in charge.
- 9. The work must be completed within _____ days from signing contract including mobilization at site.
- 10. No advance payment will be made for this work.
- 11. Mistree will be paid as below:
 - a. Total amount _____ tk for the entire construction.
 - b. Nature of payment will be _____, etc.
- 12. Mistree will be fully equipped for the connection from WASA line.
- 13. The Purchase Committee will provide all materials/ components according to the given design and specification.
- 14. The Purchase Committee will ensure safe custody of the materials procured
- 15. The final payment will be paid upon certification from community representative and Partner Organization's Engineer on satisfactory work.

Des.	Rate	Qty.	Man-days	Total
1. Skilled mistree	?00	X	XX	XXX
2. Skilled labor	?00	X	XX	XXX
3. Unskilled labor	?00	X	XX	XXX
4. Shuttering	???	X	XX	XXX
5. Others	???	X	XX	XXX
Total =				XXXX

Agreed by _____

(Name:)
Date: _____

Signature _____

Name _____
Community Representative, Purchase Committee
Date: _____

Signature: _____

Name _____
PO's Representative, Purchase Committee
Date: _____

Annex-7

..... (Name of Partner Organization)

**Advancing Sustainable Environmental Health
UWP / USP Completion Report**

(Original copy to be kept at PO's office)

A. Water Point/ Stand Post Identification :

- 1. **Water Point/ Stand Post** Identification Code:
- 2. **Water Point/ Stand Post** Model:
- 3. Name of President, CBO:
- 4. No. of Cluster/ CBO: 5. Ward No:
- 6. Slum: 7. City:

B. Contract Identification:

- 1. Name & address of Mason group leader:
- 2.a) Work Order No: 2.b) Work Order Date:

C. Water Point/ Stand Post Completion Detail:

- 1. Construction start date: 2. Construction completion date:
- 3. Service pipe from WASA supply main (ft): 4. Size of Meter Pit:
- 5. Size of reservoir (if applicable): 6. Size of Platform:
- 7. Applicable for networking WP, a) No. of Platform: b) No. of junction box:
- c) Networking pipe in total: d) farthest point from reservoir (ft):
- 8. Availability of proper drainage channel: Yes No 9. Reservoir disinfected (after construction): Yes No
- 10. Status of Water quality: a) E.Coli: b) Turbidity:
- c) Free residual Chlorine: d) pH:
- 11. Status of WASA supply (continuous/ hrs.per day):
- 12. Construction completed as per design: Yes No
- 13. Water Point/ Stand Post constructed at the site mentioned in the application form: Yes No

We certify that above statements are true.

Acknowledged by:

Name: (PO)
Signature & date

Name: President, CBO's
Signature & date

Annex-8

..... (Name of Partner Organization)

**Advancing Sustainable Environmental Health
Handing Over Note**

(Original copy to be handed over to users while the photocopy to be kept at PO's Office)

Handing Over Date:

Partner Organization's Office:

A. Water Point/ Stand Post Identification:

- 1. **Water Point/ Stand Post** Identification Code:
- 2. **Water Point/ Stand Post** Model:
- 3. Name of President, CBO:
- 4. No. of Cluster/ CBO: 5. Ward No:
- 6. Slum: 7. City:

B. Water Point/ Stand Post Completion Detail:

- 1. Construction start date: 2. Construction completion date:
- 3. Service pipe from WASA supply main (ft): 4. Size of Meter Pit:
- 5. Size of reservoir (if applicable): 6. Size of Platform:
- 7. Applicable for networking WP, a) No. of Platform: b) No. of junction box:
- c) Networking pipe in total (ft): d) Farthest point from reservoir (ft):
- 8. Availability of proper drainage channel: Yes No 9. Reservoir disinfected: Yes No
(after construction):
- 10. Status of Water quality: a) E.Coli: b) Turbidity:
- c) Free residual Chlorine: d) pH:
- 11. Status of WASA supply (continuous/ hrs.per day):

C. Other Information:

- 1. Name and address of Mason group leader:
- 2. Name of Purchase Committee Members
Community:
- Partner Organization:

D. Total Construction Cost (actual): Tk.

..... (Name of Partner Organization)

Advancing Sustainable Environmental Health

Water Point/ Stand Post Completion Report

For Partner's Official Use Only

Users Acknowledgement

(In case of Acceptable **Water Point/ Stand Post**)

We, the users, hereby acknowledge that the construction of **Water Point/ Stand Post** is satisfactory in our opinion.

We shall use and be responsible for operation and maintenance of the **Water Point/ Stand Post** regularly.

Witness (One of the users)

On behalf of the users

.....
Signature

.....
Signature

Name:.....

Name of President, CBO:.....

Date:.....

Date:.....

Handed over by:

.....
Manager/ Coordinator of Partner Organization

Date:.....

Technical Details

Step by Step

IMPLEMENTATION GUIDELINES
for Urban Water Point / Stand Post

ANNEX- 9
Technical details of Urban
Water Point/Stand Post

DRAFT

URBAN

February 2007

CONTACT

WaterAid Bangladesh

*House 97/B, Road 25, Block – A
Banani, Dhaka, 1213
Bangladesh*

Tel. ++880 (0)2 881 5757, 881 8521

Tel/Fax: ++880 (0)2 881 8521

Email: info@wateraidbd.org

Web: www.wateraid.org

TABLE OF CONTENTS

Basic Design & site selection criteria

Limitations

Operation & Maintenance

Simple Field test for materials

Design Specification

Design Parameters & calculation

Details design of Urban Water Point (UWP)/Stand Post (USP)

Model UWP-01

Model UWP-02

Model UWP-03

Model UWP-04

Model UWP-05

Model USP

Cost Estimate of Urban Water Point (UWP)/Stand Post (USP)

Model UWP-01

Model UWP-02

Model UWP-03

Model UWP-04

Model UWP-05

Model USP

Basic Design & site selection criteria

- The distance between water reservoir and water supply main should not be more than 1500 feet.
- Need to ensure minimum water consumption rate 23 liter/capita / day [20 lpcd for drinking and cooking purposes + 3 lpcd for sanitation and hygiene purposes]
- Annual Flood level should be considered during construction (Platform and reservoir)
- Need to be careful about the pipe layout. It should be slightly downward slope towards reservoir.
- Platform size should not be less than 5'x 5'
- Proper drainage system to dispose waste water from the platform
- Try to avoid installing water point near to the water body/ ditch/ drain/ latrines
- The manhole with manhole cover should be raised up to 3" from the top of the water reservoir
- Meter pit with cover should be raised at least 6" from the ground level and connect the conduit and the meter properly to avoid stagnant water in the meter pit.
- Use Non return valve and Gate valve to prevent back flow & overflow.
- Proper compaction of soil – 6" deep sand layer at the bottom of the reservoir
- For brick reservoir-
 - 10" brick wall
 - The thickness of the plaster with net cement finishing should be at least 0.5" at the inside of the reservoir.
 - proper pointing and plastering should be done at the outside of the reservoir
- For Ferro cement reservoir –
 - Depend on the availability of the required space
 - Try to avoid in poor soil condition
 - Use trained & skilled mason for construction
 - need close supervision
 - Cement sand ratio 1:2. Sylhet sand and local fine sand ratio 1:1
 - 0.5 inch chicken wire mesh should be used
- The quality of construction material should be checked- use field test method
- ASEH policy principles should be followed for site selection

Limitations:

- If water source is very far from the proposed water point location then this type of technology is tough to implement.
- If water supply is not available on a regular basis then it creates a hazard for the users.
- Close supervision & monitoring is required when construction work is being carried out.
- Users have to be hygiene conscious to prevent them contaminating the water on collection.
- Initially construction cost is relatively high for the urban poor.
- Limited land in the slum areas.

- Need strong management committee.
- Slum Eviction

Operation & Maintenance

- Pay WASA bills regularly.
- Clean the water reservoir periodically. Before cleans the reservoir hand, foot and the cloth has to be cleaned.
- Sanitary Inspection & Bacteriological test for the water point has to do quarterly basis. If bacteria found in the water than take initiative to clean the reservoir of the water points. At present
- Check the supply pipe regularly. If any trouble has been identified take rapid action.
- Clean the surroundings of the water point regularly.
- Control any possibility of contamination of the reservoir water by any foreign particles.
- Check different joints of the water point regularly.
- Check the operation of the meter regularly.
- Surroundings of the reservoir should not watery for any time.

Simple Field test for materials

#	Material	Simple field tests performed to ensure good quality
1	Cement	<ul style="list-style-type: none"> - See a uniform greenish-grey colour - A handful of cement should float on the surface of a bucket of water, - It should feel cool when a hand is thrust into the bag, - It should feel smooth when held between two fingers.
2	Sand	<ul style="list-style-type: none"> - It should be of pure silica, - It should be free from clay, silt, organic material, shells, salt,
3	Brick	<ul style="list-style-type: none"> - Should be uniform in colour, shape and standard size - Should be sound and compact: try to mark the surface with a nail and if it is easy then quality is probably not good, - Strike it with a hammer and it should give a clear ringing or metallic sound, - Should not be over or under-burned, - Bricks should not break if you form a 'tee' from 2 bricks then drop them from a height of six feet onto a fairly solid surface.
4	Aggregate	<ul style="list-style-type: none"> - Use 'Jhama' brick, - Should be free from clay, silt, organic matter, shells and salt, - Should be dry/free of moisture, - Should be angular in shape
5	Reinforcement bars	<ul style="list-style-type: none"> - Should not be split, - Should be free of corrosion.

Design Specification

- Filling sand: fine local sand having min. F.M- 0.8
- Brick: 1st class brick free from any defects. Cracking strength 5000- 8000 psi
- Coarse sand: good quality local coarse sand free from clay, silt, organic matter, shells. Local sand F.M- 1.2 and Sylhet sand F.M- 2.5
- Cement: normal Portland cement 50kg/ bag. Initial setting time 40-50 minutes. Final setting time 8- 12 hours. BDS 232 & ASTM standards.
- MS rod: 40 grade deformed bar with min $f_s = 20000$ psi, $f_y = 40000$ psi
- Brick Chips : Picked Jhama brick chips 20mm down well graded
- Mass concrete: cement :sand: brick chips= 1:2:4
- No. 6 hand pump: Unicef standard

Design parameters & Calculation

A.	Target Families	= 40	Nos. families
B.	Target Present Population, P_p	= 192	Nos.
	Average Per Day per Capita		
C.	Consumption, q	= 25	liters
D.	Total requirement $Q_d = fqP_p(1+r)^n / (1-0.01w)$	= 5558	liters (Here, Peak Factor, $f = 1.1$, $q=25$, $P_p=192$, Pop. growth rate, $r = 0$, design year $n=5$, wastage, $w = 5$)
E.	Distance from WASA main	= 300	ft
F.	Flow rate of inlet (1" WASA line), Q	1800 li/hour (0.5	li/sec)
G.	Intermittent water supply	2 times / day @ 1.5 hour	at a time
H.	Total inflow/ supply of water per day	5400	li/day
I.	Required reservoir capacity	2700 li	($Q * 1.5$)
J.	Actual reservoir Capacity	3200	liter [(7' * 4' * 4') * 28.317]
K.	No of Hand pumps	2	
L.	Size of platforms	5' * 6'	

Details design of Urban Water Point/Stand Post

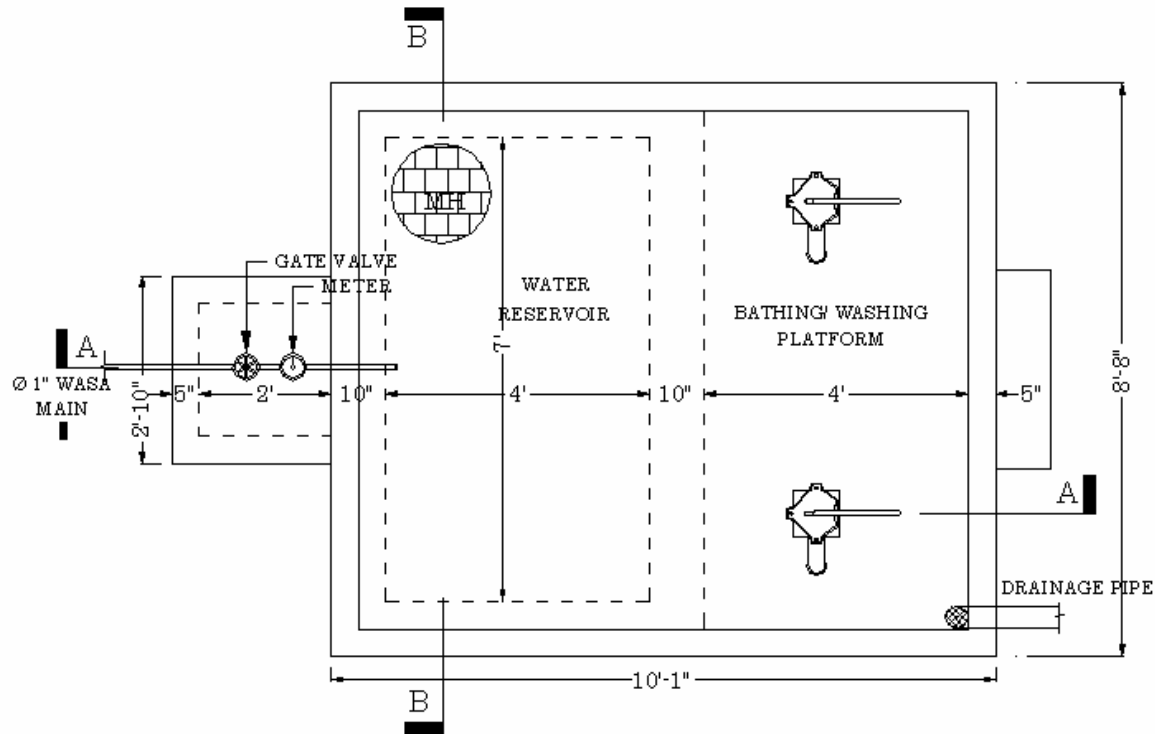

PLAN

DRAWING TITLE:

PLAN OF URBAN WATERPOINT

UWP 01
(3200 li)

DEVELOPED BY:

WaterAid Bangladesh
House # - 97/B
Road # - 25
Block - A
Banani, Dhaka-1213
Bangladesh

DESIGN CONSIDERATION:

* Total HHs = 40-60

* Average water consumption
per capita/day = 25 li.

SPECIAL NOTE:

* Depending on the soil
condition, RCC could be used
at the bottom of the reservoir

* If space is a problem TWs
could be constructed at the
top of the reservoir.

* Waste water will be
disposed off at the nearby
drain/pit.

* The depth of the reservoir
& meter pit may vary due to
the depth of the WASA
service line.

SHEET NO:

01

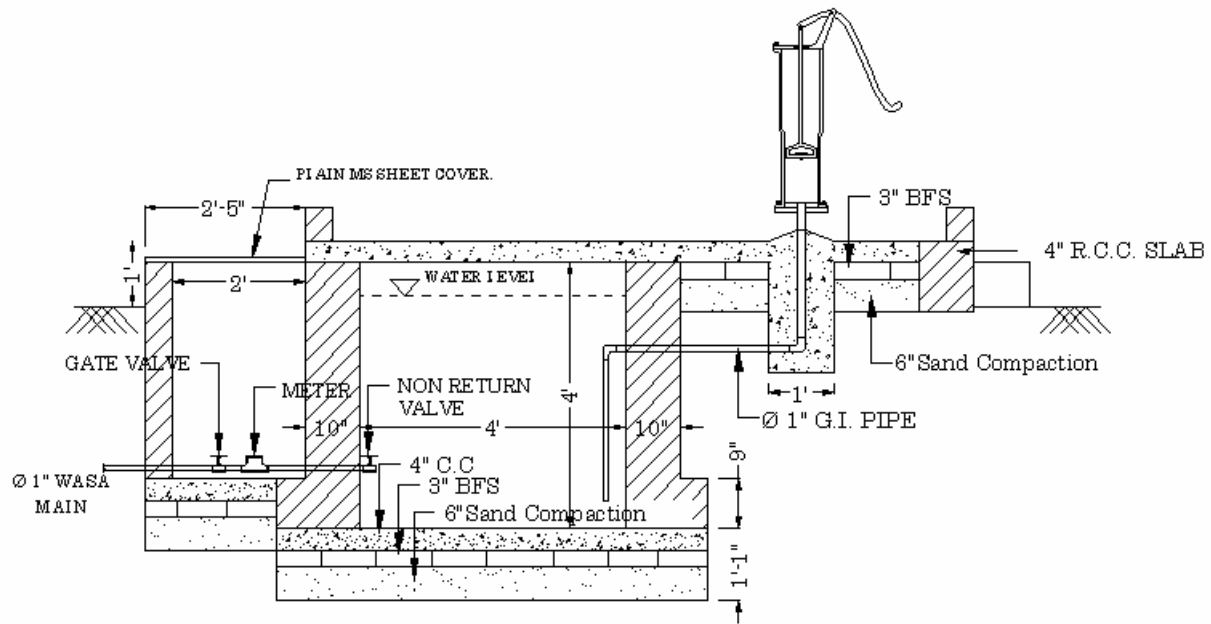

SECTION AA

DRAWING TITLE:

SECTION OF URBAN WATER POINT

UWP 01

DEVELOPED BY:

WaterAid Bangladesh
 House # - 97/B
 Road # - 25
 Block - A
 Banani, Dhaka-1213
 Bangladesh

SPECIAL NOTE:

SHEET NO:

02

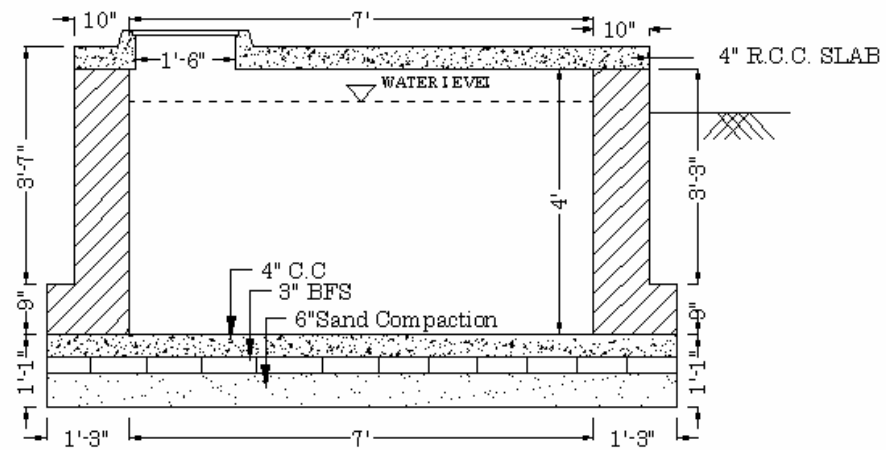

SECTION BB

DRAWING TITLE:

SECTION OF URBAN WATER POINT

UWP 01

DEVELOPED BY:

WaterAid Bangladesh
 House # - 97B
 Road # - 25
 Block - A
 Banani, Dhaka-1213
 Bangladesh

SPECIAL NOTE:

SHEET NO:

03

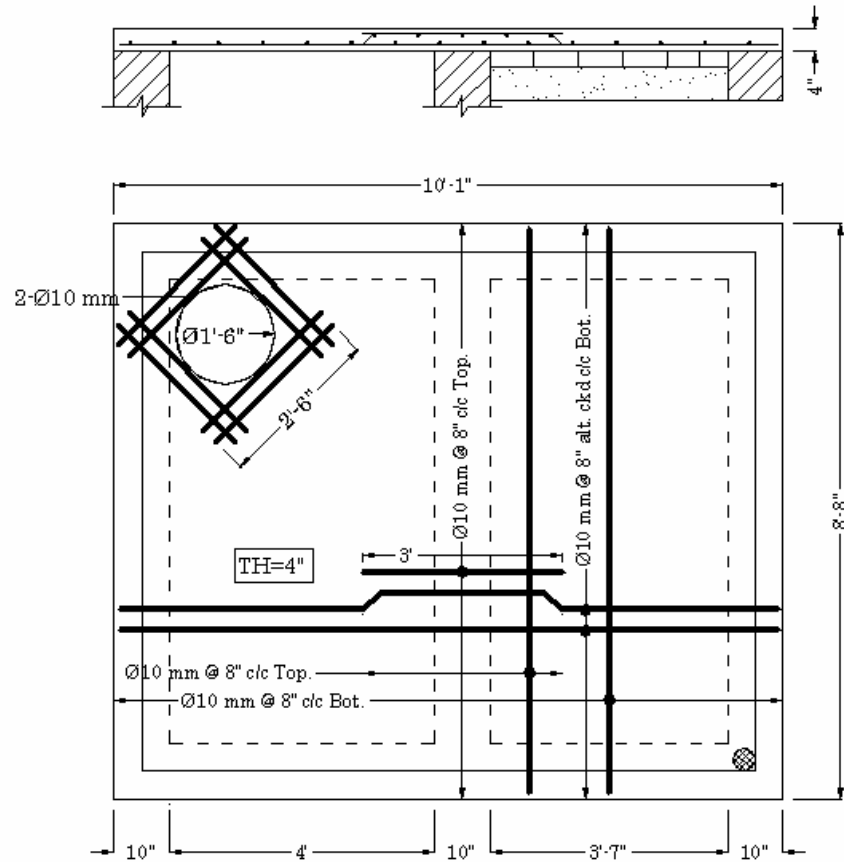

RESERVOIR TOP SLAB

DRAWING TITLE:

STRUCTURAL DESIGN OF RCC
SLAB

UWP 01

DEVELOPED BY:

WaterAid Bangladesh
House # - 97/B
Road # - 25
Block - A
Banani, Dhaka-1213
Bangladesh

SPECIAL NOTE:

$f'c = 2500$ psi
 $f_y = 40000$ psi

SHEET NO:

04

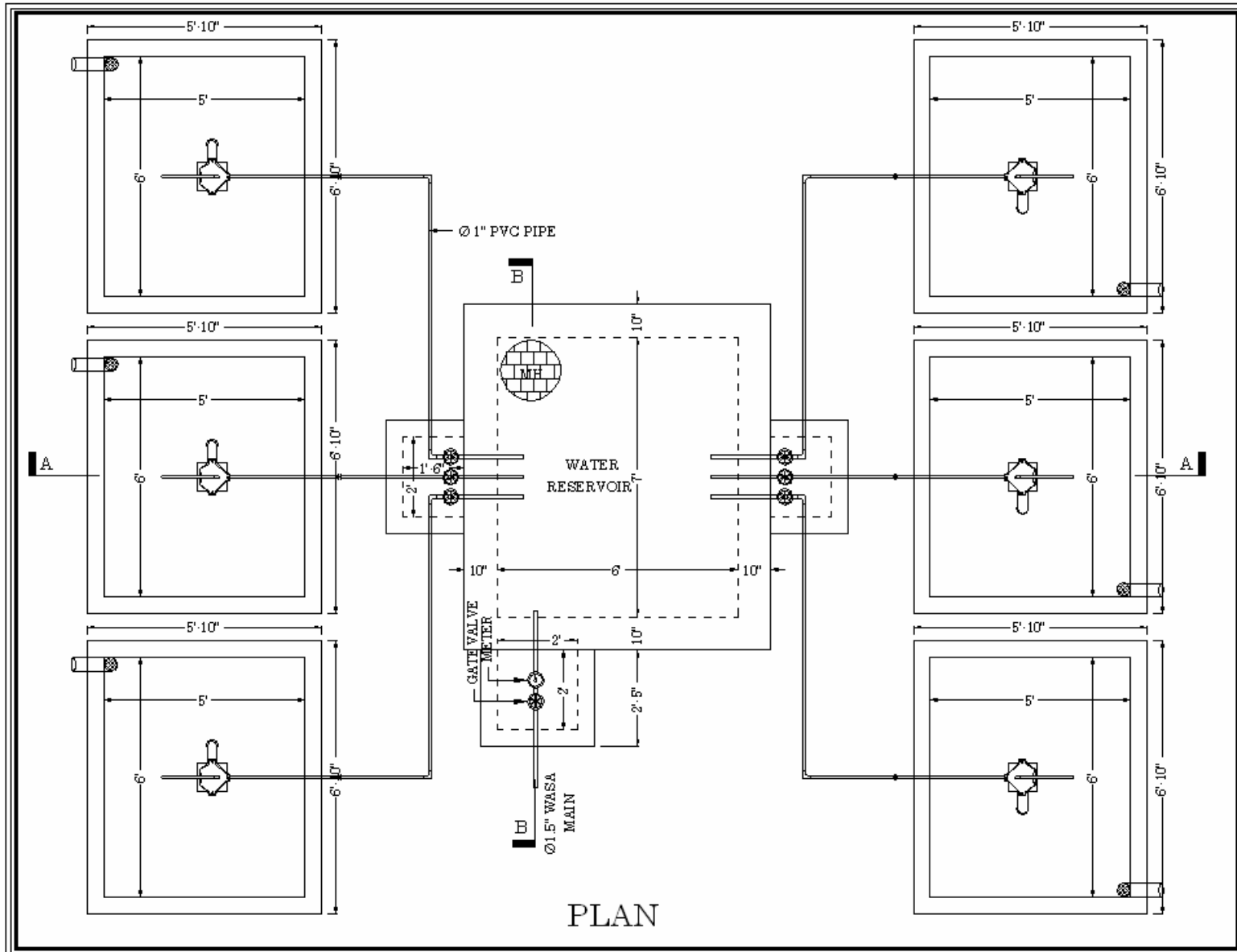

PLAN

DRAWING TITLE:
PLAN OF URBAN WATER POINT UWP - 02 (6000 l)
DEVELOPED BY:
WaterAid Bangladesh House # - 97/B Road # - 25 Block - A Banani, Dhaka-1213 Bangladesh.
DESIGN CONSIDERATION:
* Total HHs = 90-120 * Average water consumption per capita/day = 25 li.
SPECIAL NOTE
* Depending on the soil condition, RCC could be used at the bottom of the reservoir. * Waste water will be disposed off at the nearby drain/pit. * The depth of the reservoir & meter pit may vary due to the depth of the WASA service line. * The distance from reservoir to platform should not be more than 100 ft.
SHEET NO:
01

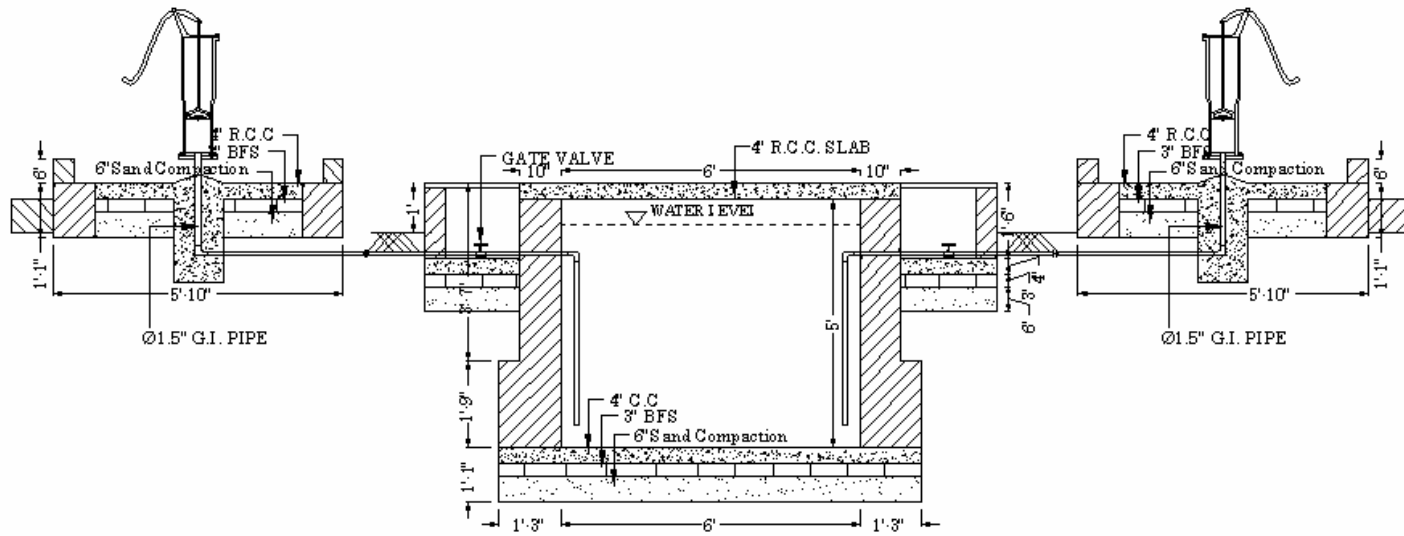

SECTION AA

DRAWING TITLE:

PLAN OF URBAN WATER POINT

UWP - 02

DEVELOPED BY:

WaterAid Bangladesh
 House # - 97/B
 Road # - 25
 Block - A
 Banani, Dhaka-1213
 Bangladesh.

SPECIAL NOTE:

SHEET NO:

02

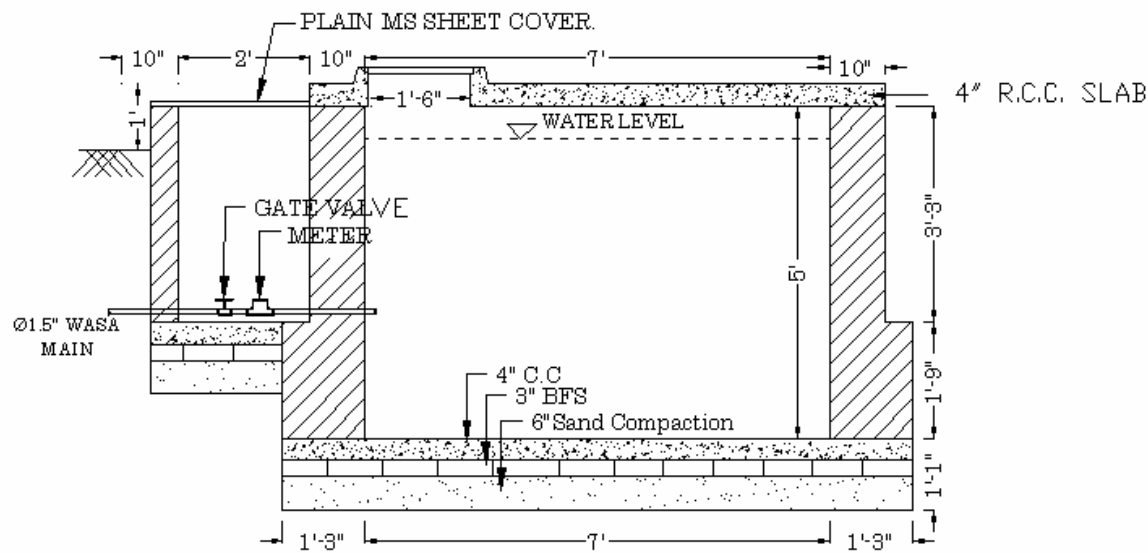

SECTION BB

DRAWING TITLE:

SECTION OF URBAN WATER POINT

UWP 02

DEVELOPED BY:

Water Aid Bangladesh
 House # - 97/B
 Road # - 25
 Block - A
 Banani, Dhaka-1213
 Bangladesh

SPECIAL NOTE:

SHEET NO:

03

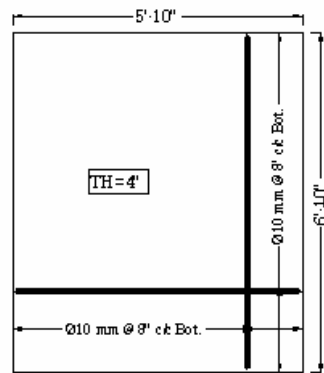

BATHING/ WASHING
PLATFORM
(IF REQUIRED)

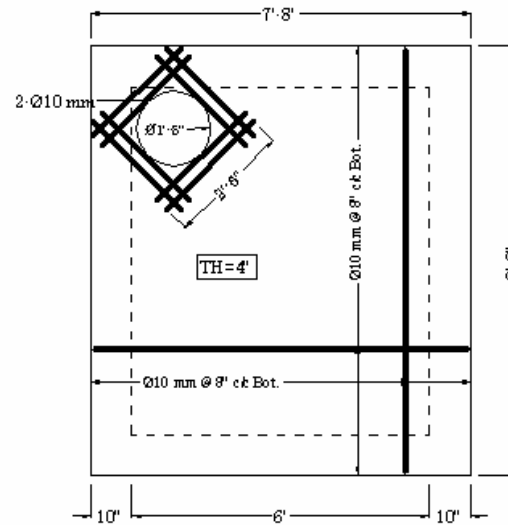

RESERVOIR TOP SLAB

DRAWING TITLE:

STRUCTURAL DESIGN OF R.C.C
SLAB

UWP · 02

DEVELOPED BY:

WaterAid Bangladesh
House # · 97/B
Road # · 25
Block · A
Banani, Dhaka-1213
Bangladesh.

SPECIAL NOTE:

$f'c = 2500$ psi
 $f_y = 40000$ psi

SHEET NO:

04

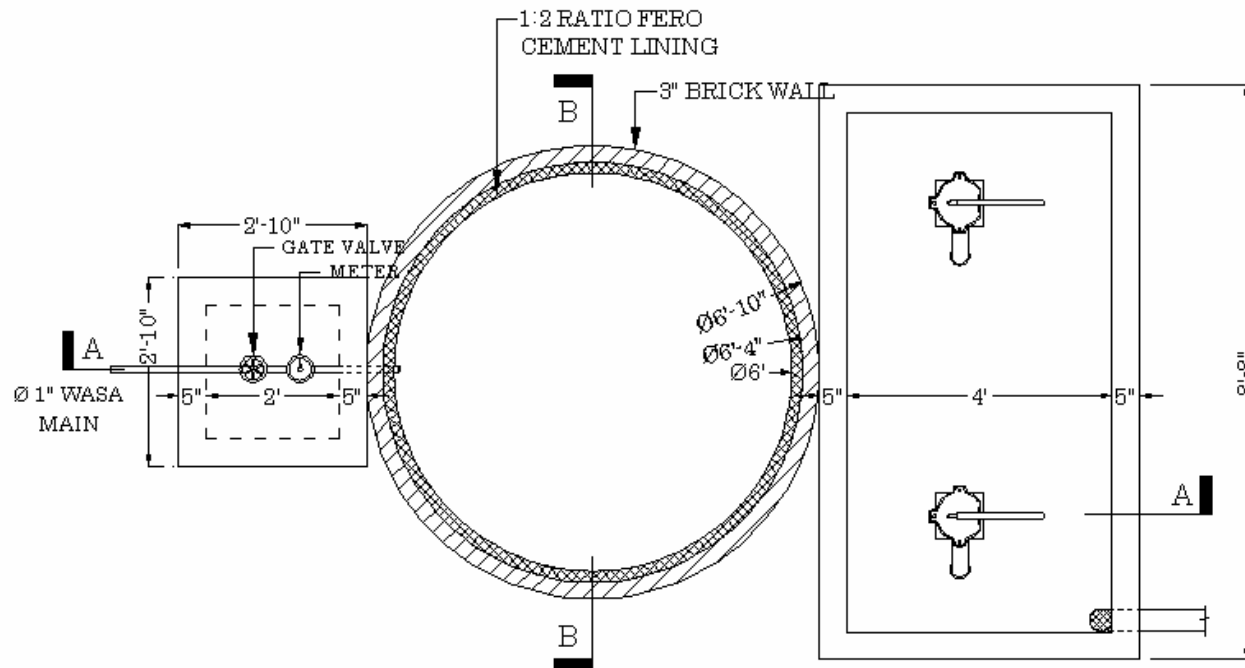

PLAN

DRAWING TITLE :

PLAN OF URBAN WATER POINT

UWP 03

DEVELOPED BY:

WaterAid Bangladesh
 House # - 97/B
 Road # - 25
 Block - A
 Banani, Dhaka-1213
 Bangladesh

DESIGN CONSIDERATION:

* Total HHs = 40-60

* Average water consumption
 per capita/day = 25 li.

SPECIAL NOTE:

* Depending on the soil
 condition, RCC could be used
 at the bottom of the reservoir.

* Waste water will be
 disposed off at the nearby
 drain/pit.

* The depth of the reservoir
 & meter pit may vary due to
 the depth of the WASA
 service line.

SHEET NO:

01

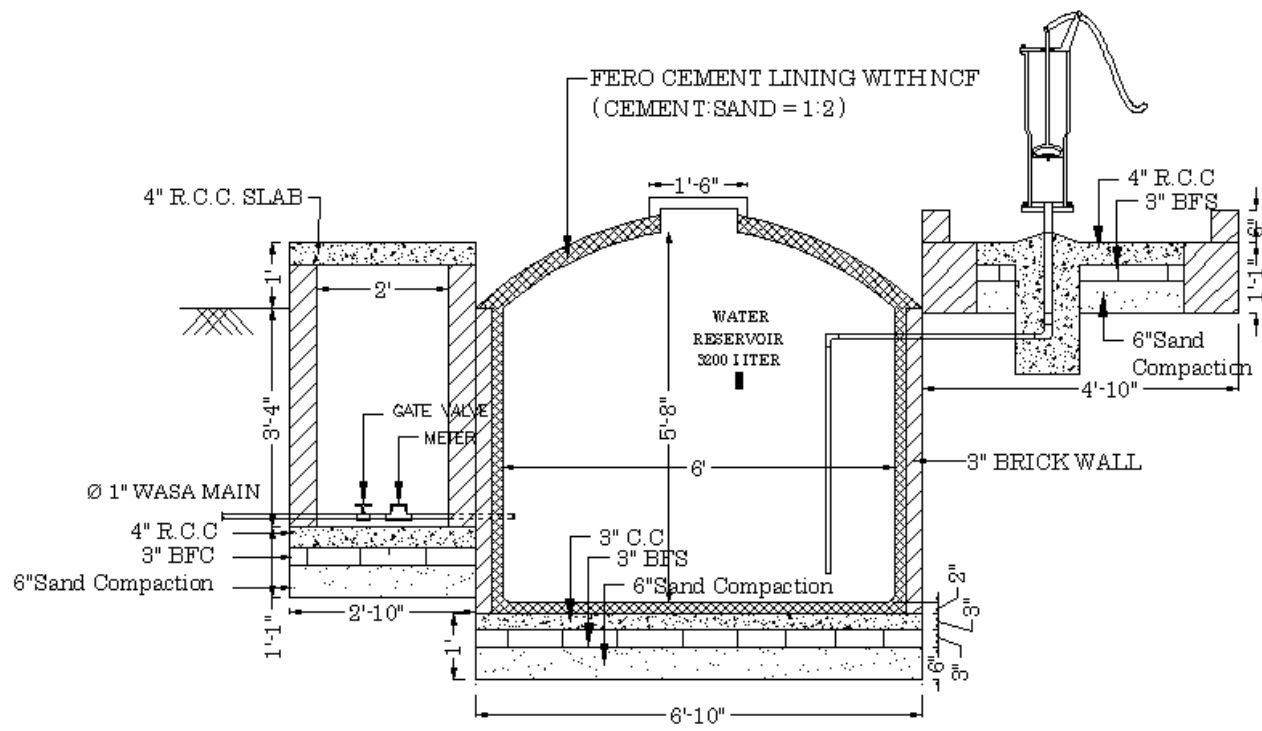

SECTION AA

DRAWING TITLE:

SECTION OF URBAN WATER POINT

UWP 03

DEVELOPED BY:

WaterAid Bangladesh
 House # - 97/B
 Road # - 25
 Block - A
 Banani, Dhaka-1213
 Bangladesh

SPECIAL NOTE:

SHEET NO:

02

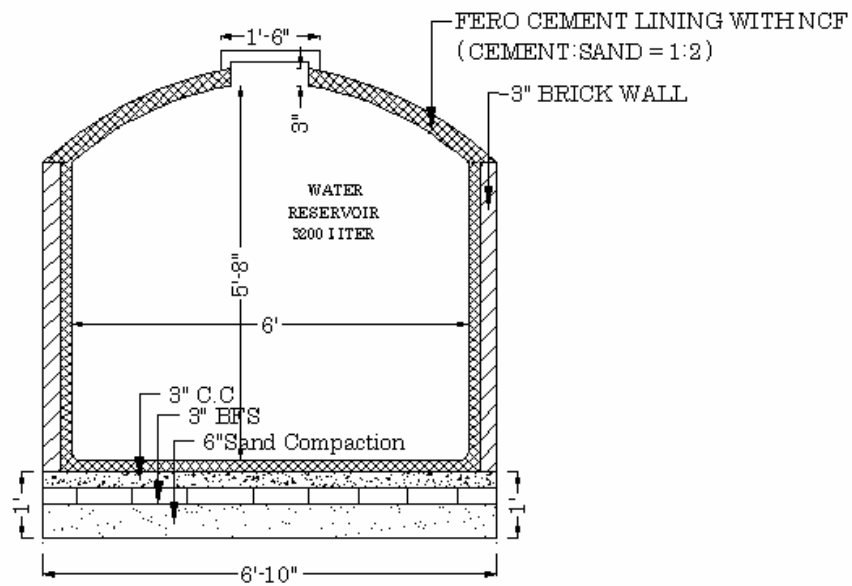

SECTION BB

DRAWING TITLE:

SECTION OF URBAN WATER POINT

UWP 03

DEVELOPED BY:

WaterAid Bangladesh
House # - 97/B
Road # - 25
Block - A
Banani, Dhaka-1213
Bangladesh

SPECIAL NOTE:

SHEET NO:

03

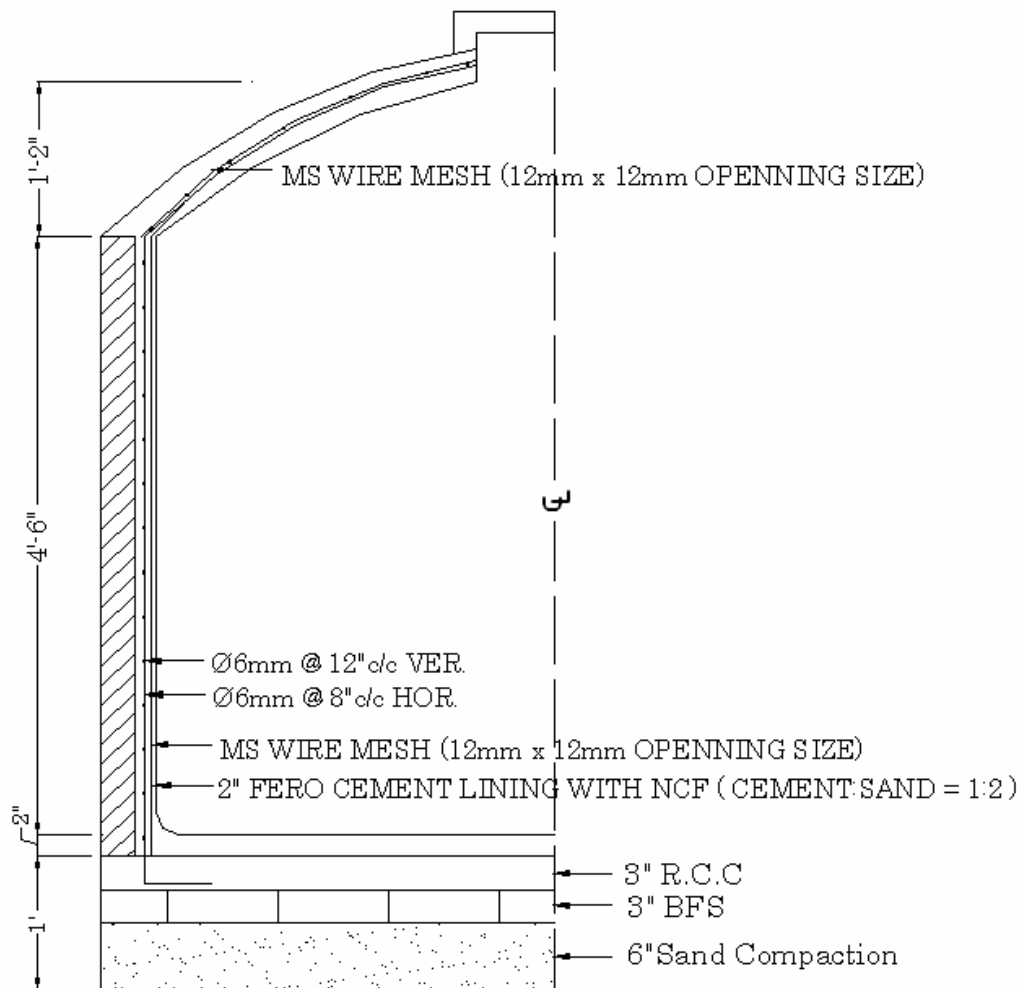

DRAWING TITLE:
SECTION OF URBAN WATER POINT UWP 03
DEVELOPED BY:
Water Aid Bangladesh House # - 97/B Road # - 25 Block - A Banani, Dhaka-1213 Bangladesh
SPECIAL NOTE:
SHEET NO:
04

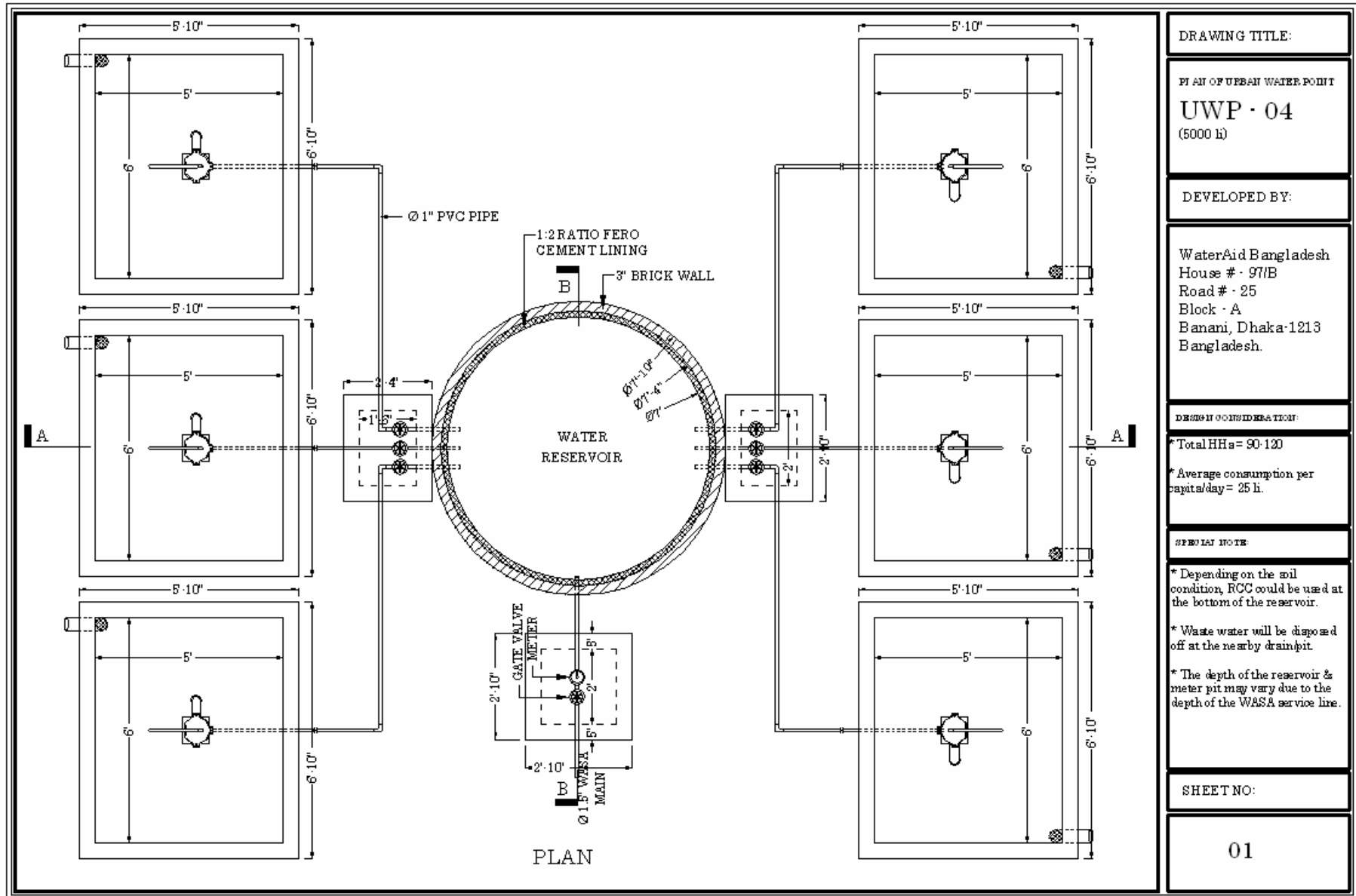

DRAWING TITLE:

PLAN OF URBAN WATER POINT
UWP · 04
 (6000 l)

DEVELOPED BY:

WaterAid Bangladesh
 House # · 97/B
 Road # · 25
 Block · A
 Banani, Dhaka-1213
 Bangladesh.

DESIGN CONSIDERATION:

* Total HHs = 90-120
 * Average consumption per capita/day = 25 li.

SPECIAL NOTE:

* Depending on the soil condition, RCC could be used at the bottom of the reservoir.
 * Waste water will be disposed off at the nearby drain/pit.
 * The depth of the reservoir & meter pit may vary due to the depth of the WASA service line.

SHEET NO:

01

DRAWING TITLE:
 PLAN OF URBAN WATER POINT
 UWP - 04

DEVELOPED BY:
 WaterAid Bangladesh
 House # - 97/B
 Road # - 25
 Block - A
 Banani, Dhaka-1213
 Bangladesh.

SPECIAL NOTE:

SHEETNO:

02

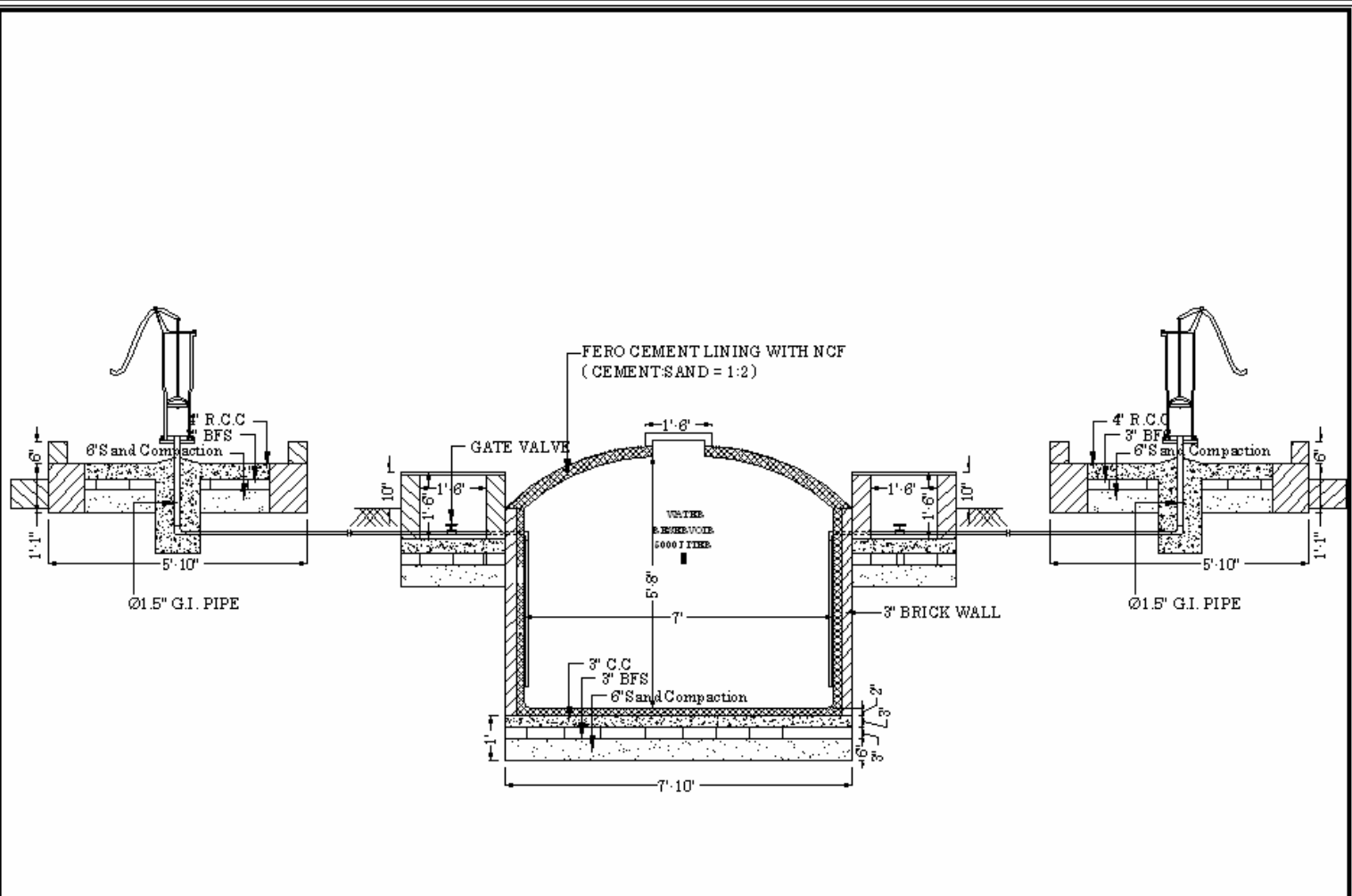

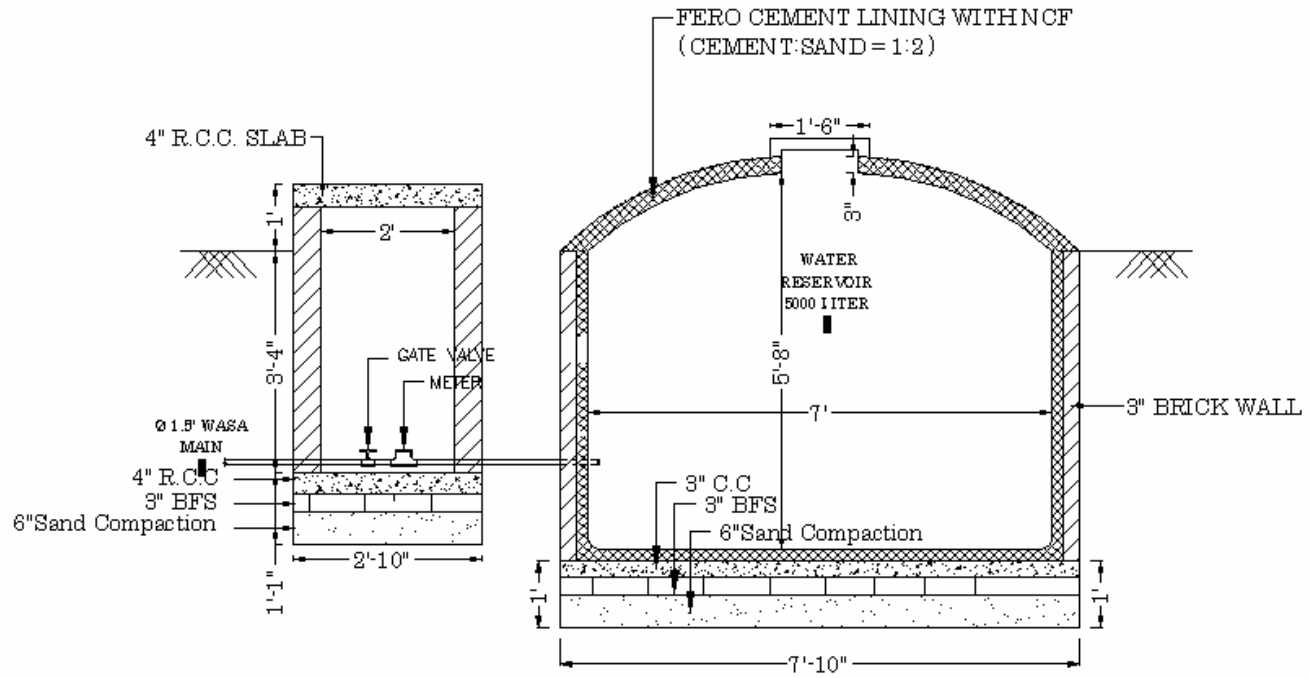

SECTION BB

DRAWING TITLE :

SECTION OF URBAN WATER POINT

UWP 04

DEVELOPED BY:

WaterAid Bangladesh
House # - 97/B
Road # - 25
Block - A
Banani, Dhaka-1213
Bangladesh

SPECIAL NOTE:

SHEET NO:

03

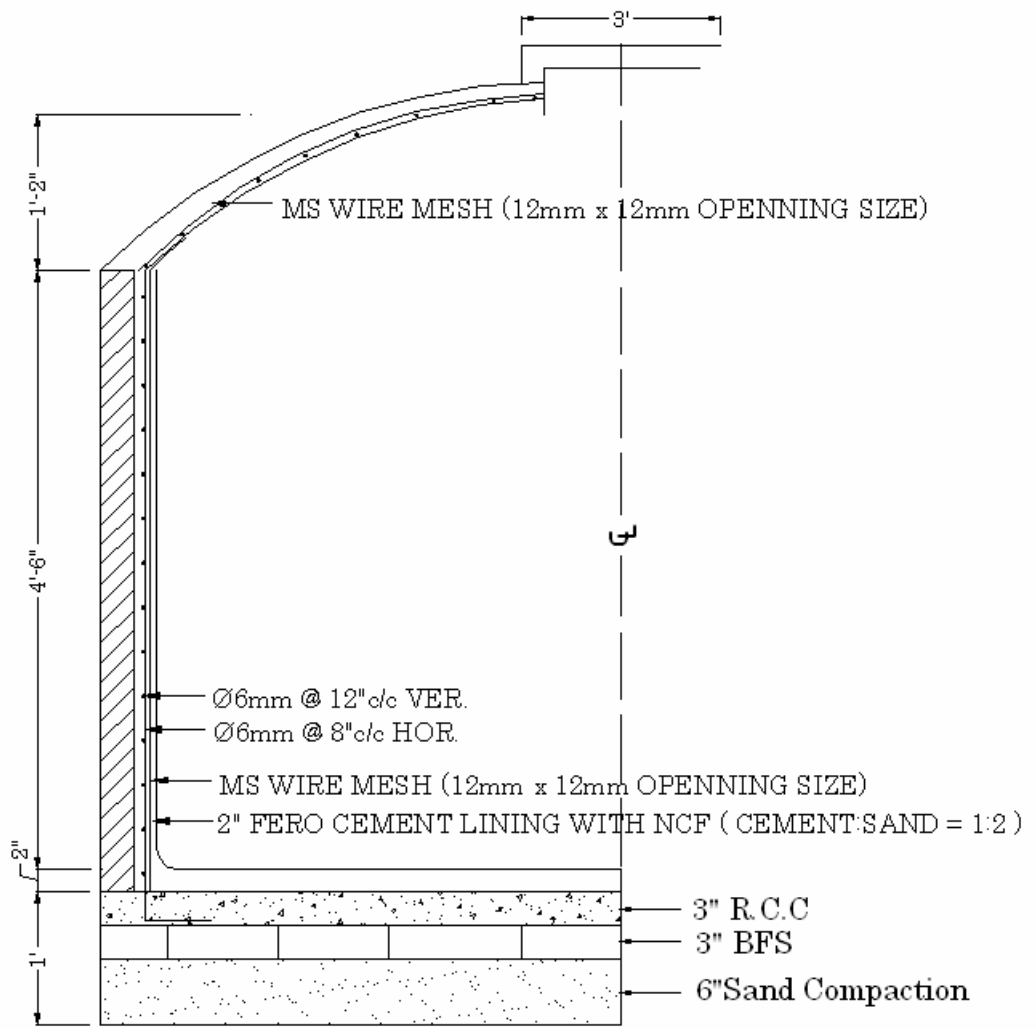

DRAWING TITLE:
SECTION OF URBAN WATER POINT
UWP 04
DEVELOPED BY:
Water Aid Bangladesh House # - 97/B Road # - 25 Block - A Banani, Dhaka-1213 Bangladesh
SPECIAL NOTE:
SHEET NO:
04

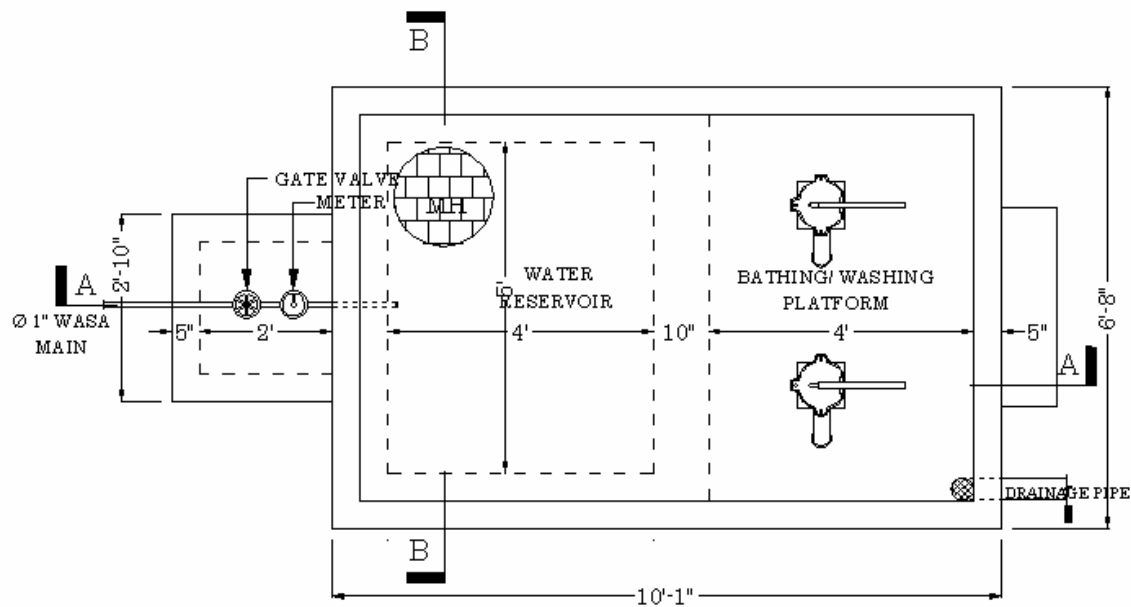

PLAN

DRAWING TITLE:

PLAN OF URBAN WATER POINT

UWP 05
(2200 li)

DEVELOPED BY:

WaterAid Bangladesh
House # - 97/B
Road # - 25
Block - A
Banani, Dhaka-1213
Bangladesh

DESIGN CONSIDERATION:

* Total HHS = 25-40

* Average consumption per capita/day = 25 li.

SPECIAL NOTE:

* Depending on the soil condition, RCC could be used at the bottom of the reservoir.

* If space is a problem TWs could be constructed at the top of the reservoir.

* Waste water will be disposed off at the nearby drain/pit.

* The depth of the reservoir & meter pit could vary due to the depth of the WASA service line.

SHEET NO:

01

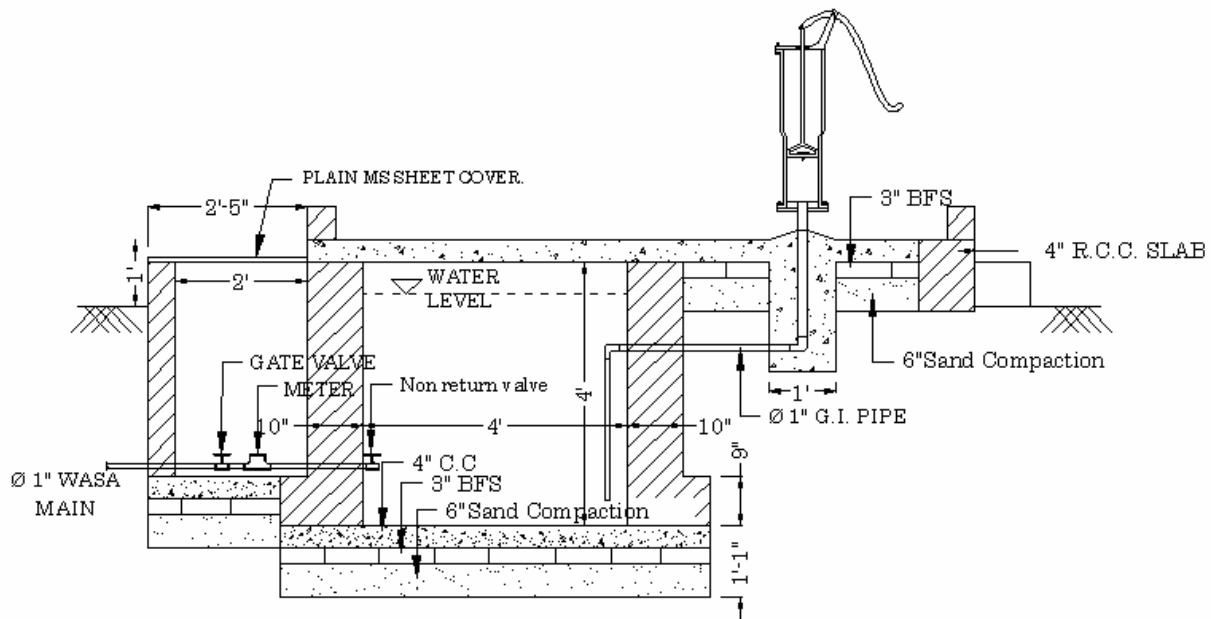

SECTION AA

DRAWING TITLE:

SECTION OF URBAN WATER POINT

UWP 05

DEVELOPED BY:

WaterAid Bangladesh
 House # - 97B
 Road # - 25
 Block - A
 Banani, Dhaka-1213
 Bangladesh

SPECIAL NOTE:

SHEET NO:

02

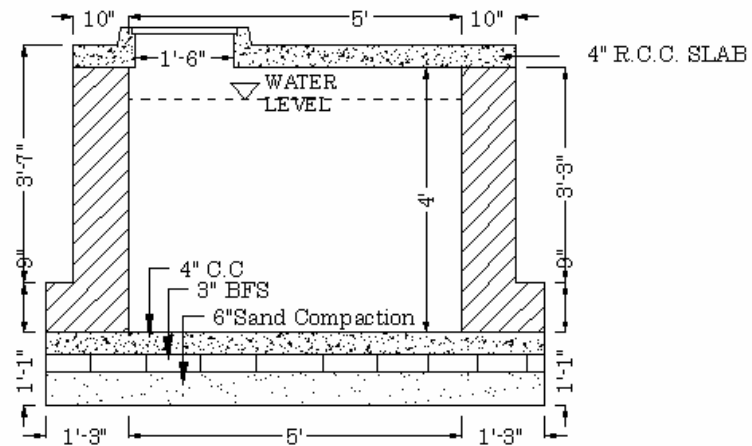

SECTION BB

DRAWING TITLE:

SECTION OF URBAN WATER POINT

UWP 05

DEVELOPED BY:

WaterAid Bangladesh
 House # - 97/B
 Road # - 25
 Block - A
 Banani, Dhaka-1213
 Bangladesh

SPECIAL NOTE:

SHEET NO:

03

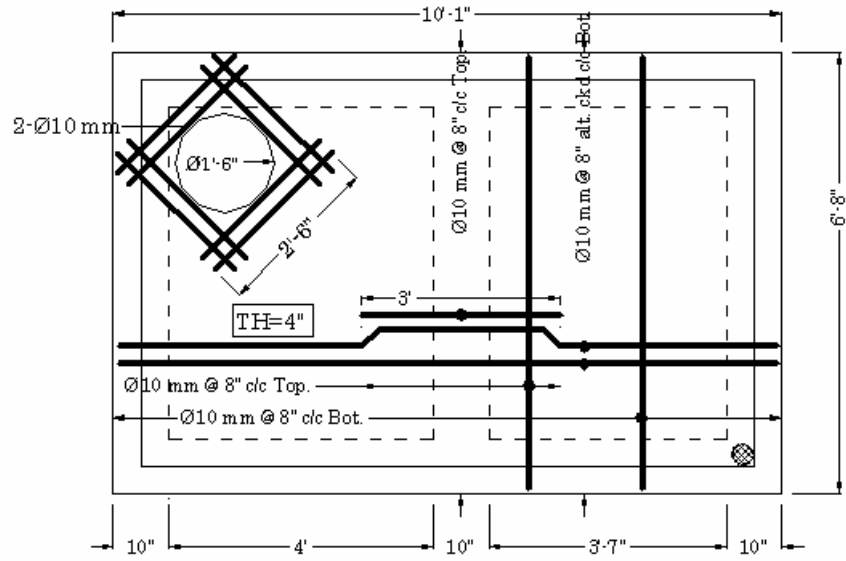
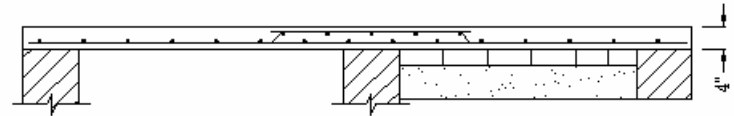

RESERVOIR TOP SLAB

DRAWING TITLE:

STRUCTURAL DESIGN OF RCC
SLAB

UWP 05

DEVELOPED BY:

WaterAid Bangladesh
House # - 97/B
Road # - 25
Block - A
Banani, Dhaka-1213
Bangladesh

SPECIAL NOTE:

$f'c = 2500 \text{ psi}$
 $f_y = 40000 \text{ psi}$

SHEET NO:

04

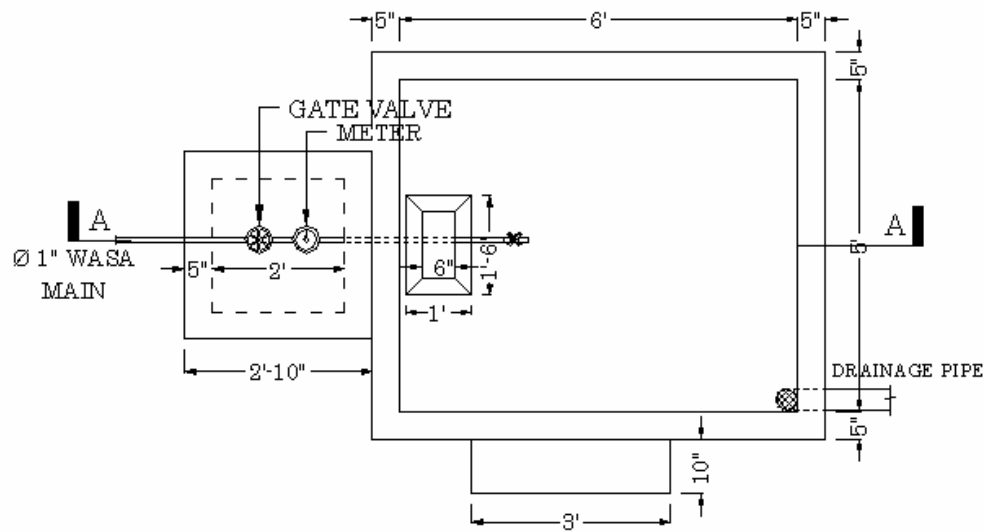

PLAN

DRAWING TITLE :

PLAN OF URBAN STAND POST

USP

DEVELOPED BY :

WaterAid Bangladesh
 House # - 97/B
 Road # - 25
 Block - A
 Banani, Dhaka-1213
 Bangladesh

DESIGN CONSIDERATION :

* Total HHs = 15-25

* Avg. consumption per capita/day = 25 l.

SPECIAL NOTE :

* No. 6 hand pump could be used instead of tap if water pressure is lower than that is required.

* Waste water will be disposed off at the nearby drain/pit.

SHEET NO :

01

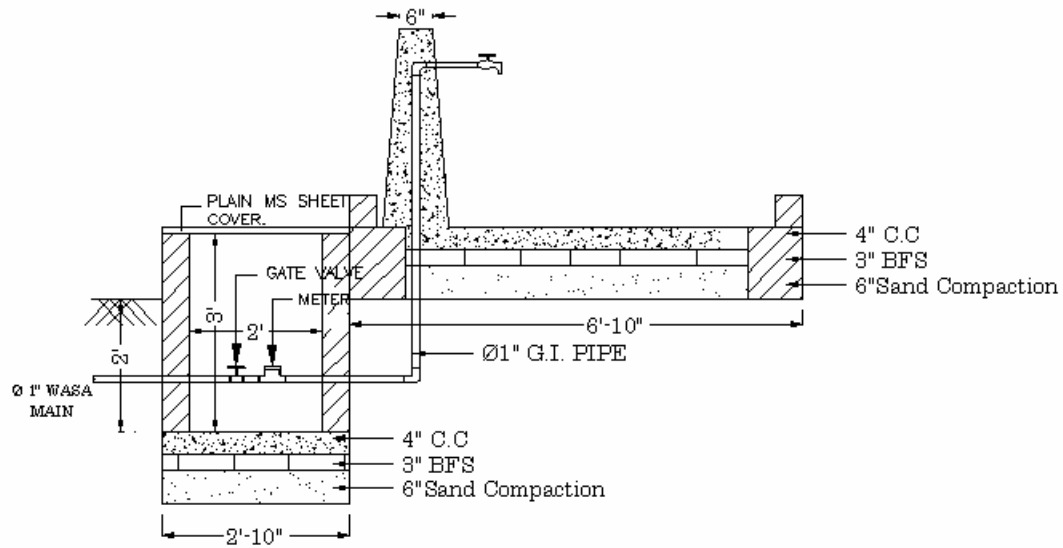

SECTION AA

DRAWING TITLE:

SECTION OF URBAN STAND
POST.

USP

DEVELOPED BY:

WaterAid Bangladesh
House # - 97/B
Road # - 25
Block - A
Banani, Dhaka-1213
Bangladesh

SPECIAL NOTE:

SHEET NO:

02

Cost Estimate of Urban Water Point/ Stand Post

Estimated cost of Urban Water Point
Model no. UWP 01
Reservoir capacity 3200 liters

RESERVOIR						
Sl. No.	Name of the Item of Work/Materials	Quantity	Unit	Unit price	Amount in Taka	Remarks
1	Earthwork	355	cft	0.00	0.00	
2	Bricks	1265	nos.	4.20	5313.00	
3	Filling Sand	52	cft	12.00	624.00	
4	Sand(FM 1.2 to 2.5)	75	cft	18.50	1387.50	
5	Cement	18	bag	330.00	5940.00	
6	Khoa	45	cft	45.00	2025.00	
7	Manhole cover	1	nos.	900.00	900.00	
8	MS Rod (#3 deformed bar)	97	kg	45.00	4365.00	
9	Shuttering/Centering	94	sft	15.00	1410.00	
Total					21964.50	

Meter Pit						
Sl. No.	Name of the Item of Work/Materials	Quantity	Unit	Unit price	Amount in Taka	Remarks
1	Earthwork	38.3	cft		0.00	
2	Bricks	125	nos.	4.20	525.00	
3	Filling Sand	6.21	cft	12.00	74.52	
4	Sand(FM 1.2 to 2.5)	8.79	cft	18.50	162.62	
5	Cement	2	bag	330.00	660.00	
6	Khoa	2	cft	45.00	90.00	
7	Meter pit cover -MS Sheet 14BWG	1	piece	1500.00	1500.00	
8	Lock	1		50.00	50.00	
Total					3062.14	

Bathing/Washing Platform						
Sl. No.	Name of the Item of Work/Materials	Quantity	Unit	Unit price	Amount in Taka	Remarks
1	Earthwork	6	cft		0.00	
2	Bricks	345	nos.	4.20	1449.00	
3	Filling Sand	17	cft	12.00	204.00	
4	Sand(FM 1.2 to 2.5)	15	cft	18.50	277.50	
5	Cement	3	bag	330.00	990.00	
6	Khoa	2	cft	40.00	80.00	
7	Tube well	2	nos.	1400.00	2800.00	
Total					5800.50	

Plumbing						
Sl. No.	Name of the Item of Work/Materials	Quantity	Unit	Unit price	Amount in Taka	Remarks
1	G. I. Pipe (short piece)	5	rft	70.00	350.00	
2	G. I. Pipe (short piece) 1.5"	6	rft	110.00	660.00	
3	Non-return valve	1	nos.	300.00	300.00	
4	1" Gate valve	1	nos.	300.00	300.00	
5	Thread tape	5	nos.	15.00	75.00	
6	Nut	8	nos.	10.00	80.00	
7	Nipple	2	nos.	40.00	80.00	
8	Socket	6	nos.	30.00	180.00	
9	Elbow	2	nos.	35.00	70.00	
10	reducer (1"- 1.5")	2		50.00	100.00	
Total					2195.00	

WASA						
Sl no	Name of the materials	Quantity	Unit	Unit price	Amount in Taka	Remarks
1	WASA Connection form	1		100	100	
2	WASA Dimand note	1		2500	2500	
3	WASA Security	1		1000	1000	
4	Meter & meter testing	1		4000	4000	
	Entertainment/mobilization				1000	
5	Total				8600	

WASA CONNECTION (1" @ coil pipe)- 500 ft						
Sl no	Name of the materials	Quantity	Unit	Unit price	Amount in Taka	Remarks
1	GI Pipe, ft	15	ft	70	1050	
2	PVC Pipe, ft	500	ft	10	5000	
3	Earth work for Pipe laying	2400	cft	1.5	3600	
4	Clump, piece	1		450	450	
5	Plumber	1		800	800	
6	Short pieces				0	
7	Thread tape	8		15	120	
	Total				11020	

Total Material Cost	33022.14
WASA Connection	11020.00
Labour Cost	8255.53
WASA Cost	8600.00
Head carrying cost	1000.00
ASEH marking	500.00
Grand total	62397.67

Note:

- ! All rates are followed as per present highest market price. The cost may vary depending on the present market price but should not exceed $\pm 10\%$
- ! Additional cost for road cutting permission & labour will be added where necessary.
- ! Cost could vary due to the distance from Water point to WASA service main
- ! Fencing of the Water Point is optional considering the community demand.

Cost comparison of WASA conection with PVC coil pipe and GI pipe

WASA CONNECTION (1" @ coil pipe)- 500 ft						
Sl no	Name of the materials	Quantity	Unit	Unit price	Total Tk.	Remarks
1	GI Pipe, ft	15	ft	70	1050	
2	PVC Pipe, ft	500	ft	10	5000	
3	Earth work for Pipe laying	2400	cft	1.5	3600	
4	Clump, piece	1		450	450	
5	Plumber	1		800	800	
6	Short pieces				0	
7	Thread tape	8		15	120	
	Total				11020	
Total	Material Cost				33022.14	
	WASA Connection				11020.00	
	Labour Cost				8255.53	
	WASA Cost				8600.00	
	Head carrying cost				1000.00	
	ASEH marking				500.00	
Grand total					62397.67	
WASA CONNECTION (1"@ GI pipe)- 500 ft						
Sl no	Name of the materials	Quantity	Unit	Unit price	Total Tk.	Remarks
1	1" @GI Pipe	500	ft	70	35000	
2	1" socket	20	nos	18	360	
3	1" elbow	10	nos	25	250	
4	Earth work for Pipe laying	2520	cft	1.5	3780	
5	Clump, piece	1		450	450	
6	Plumber	3	mandays	800	2400	
7	Short pieces				0	
8	Thread tape	8		15	120	
	Total				42360	
Total	Material Cost				33022.14	
	WASA Connection				42360.00	
	Labour Cost				8255.53	
	WASA Cost				8600.00	
	Head carrying cost				1000.00	
	ASEH marking				500.00	
Grand total					93737.67	
WASA CONNECTION (1" @ coil pipe)- 1000 ft						
Sl no	Name of the materials	Quantity	Unit	Unit price	Total Tk.	Remarks
1	GI Pipe, ft	15	ft	70	1050	
2	PVC Pipe, ft	1000	ft	10	10000	
3	Earth work for Pipe laying	4800	cft	1.5	7200	
4	Clump, piece	1		450	450	
5	Plumber	1		800	800	
6	Short pieces				0	
7	Thread tape	8		15	120	
	Total				19620	
Total	Material Cost				33022.14	
	WASA Connection				19620.00	
	Labour Cost				8255.53	
	WASA Cost				8600.00	
	Head carrying cost				1000.00	
	ASEH marking				500.00	
Grand total					70997.67	

WASA CONNECTION (1"@ GI pipe)- 1000 ft						
Sl no	Name of the materials	Quantity	Unit	Unit price	Total Tk.	Remarks
1	1" @GI Pipe	1000	ft	70	70000	
2	1" socket	30	nos	18	540	
3	1" elbow	15	nos	25	375	
4	Earth work for Pipe laying	5040	cft	1.5	7560	
5	Clump, piece	1		450	450	
6	Plumber	5	mandays	800	4000	
7	Short pieces				0	
8	Thread tape	8		15	120	
	Total				83045	
Total	Material Cost				33022.14	
	WASA Connection				83045.00	
	Labour Cost				8255.53	
	WASA Cost				8600.00	
	Head carrying cost				1000.00	
	ASEH marking				500.00	
Grand total					134422.67	
WASA CONNECTION (1" @ coil pipe)- 1500 ft						
Sl no	Name of the materials	Quantity	Unit	Unit price	Total Tk.	Remarks
1	GI Pipe, ft	15	ft	70	1050	
2	PVC Pipe, ft	1500	ft	10	15000	
3	Earth work for Pipe laying	7200	cft	1.5	10800	
4	Clump, piece	1		450	450	
5	Plumber	1		800	800	
6	Short pieces				0	
7	Thread tape	8		15	120	
	Total				28220	
Total	Material Cost				33022.14	
	WASA Connection				28220.00	
	Labour Cost				8255.53	
	WASA Cost				8600.00	
	Head carrying cost				1000.00	
	ASEH marking				500.00	
Grand total					79597.67	
WASA CONNECTION (1"@ GI pipe)- 1500 ft						
Sl no	Name of the materials	Quantity	Unit	Unit price	Total Tk.	Remarks
1	1" @GI Pipe	1500	ft	70	105000	
2	1" socket	35	nos	18	630	
3	1" elbow	20	nos	25	500	
4	Earth work for Pipe laying	7560	cft	1.5	11340	
5	Clump, piece	1		450	450	
6	Plumber	8	mandays	800	6400	
7	Short pieces				0	
8	Thread tape	8		15	120	
	Total				124440	
Total	Material Cost				33022.14	
	WASA Connection				124440.00	
	Labour Cost				8255.53	
	WASA Cost				8600.00	
	Head carrying cost				1000.00	
	ASEH marking				500.00	
Grand total					175817.67	

Estimated cost of Urban Water Point
Model no. UWP 02
Reservoir capacity 6000 liters

RESERVOIR						
Sl. No.	Name of the Item of Work/Materials	Quantity	Unit	Unit price	Amount in Taka	Remarks
1	Earthwork	549	cft		0.00	
2	Bricks	1934	nos.	4.20	8122.80	
3	Filling Sand	65	cft	12.00	780.00	
4	Sand (FM 1.2 to 2.5)	102	cft	18.50	1887.00	
5	Cement	22	bag	330.00	7260.00	
6	Khoa	42	cft	45.00	1890.00	
7	Manhole cover	1	nos.	900.00	900.00	
8	MS Rod (#3 deformed bar)	74	kg	45.00	3330.00	
9	Shuttering/Centering	59	sft	15.00	885.00	
Total					25054.80	

Meter Pit						
Sl. No.	Name of the Item of Work/Materials	Quantity	Unit	Unit price	Amount in Taka	Remarks
1	Earthwork	39	cft		0.00	
2	Bricks	125	nos.	4.20	525.00	
3	Filling Sand	6.01	cft	12.00	72.12	
4	Sand (FM 1.2 to 2.5)	8.99	cft	18.50	166.32	
5	Cement	2	bag	330.00	660.00	
6	Khoa	2	cft	45.00	90.00	
7	Meter pit cover -MS Sheet 14BWG	1	piece	1500.00	1500.00	
8	Lock	1	nos.	50.00	50.00	
Total					3063.44	

Bathing/Washing Platform (6)						
Sl. No.	Name of the Item of Work/Materials	Quantity	Unit	Unit price	Amount in Taka	Remarks
1	Earthwork	28.82	cft		0.00	
2	Bricks	2203	nos.	4.20	9252.60	
3	Filling Sand	85	cft	12.00	1020.00	
4	Sand (FM 1.2 to 2.5)	110	cft	18.50	2035.00	
5	Cement	25	bag	330.00	8250.00	
6	Khoa	45	cft	45.00	2025.00	
7	Tube well	6	Nnos.	1400.00	8400.00	
Total					30982.60	

Junction Box (2)						
Sl. No.	Name of the Item of Work/Materials	Quantity	Unit	Unit price	Amount in Taka	Remarks
1	Earthwork	28	cft		0.00	
2	Bricks	118	nos.	4.20	495.60	
3	Filling Sand	13	cft	12.00	156.00	
4	Sand (FM 1.2 to 2.5)	7	cft	18.50	129.50	
5	Cement	2	bag	330.00	660.00	
6	Khoa	4	cft	45.00	180.00	
7	MS Sheet 14BWG	2	Piece	1000.00	2000.00	
Total					3621.10	

Plumbing						
Sl. No.	Name of the Item of Work/Materials	Quantity	Unit	Unit price	Amount in Taka	Remarks
1	G. I. Pipe short pice 1.5"	30	rft	110.00	3300.00	
2	G. I. Pipe 1.5"	18	rft	110.00	1980.00	
3	Non-return valve 1.5"	1	rft	800.00	800.00	
4	check valve 1"	6	nos.	700.00	4200.00	
5	1" Gate valve	6	nos.	300.00	1800.00	
6	1" pvc coil pipe	300	rft	10.00	3000.00	
7	Thread tape	10	nos.	15.00	150.00	
8	Nut	40	nos.	10.00	400.00	
9	Nipple	8	nos.	40.00	320.00	
10	Socket	8	nos.	30.00	240.00	
11	Elbow	12	nos.	35.00	420.00	
12	Reducer (1.5"-1")	6	nos.	50.00	300.00	
Total					16910.00	

WASA (1.5" @ connection)						
Sl no	Name of the materials	Quantity	Unit	Unit price	Amount in Taka	Remarks
1	WASA Connection form	1		100	100	
2	WASA Dimand note	1		14000	14000	
3	WASA Security			2000	2000	
4	Meter & meter testing	1		6000	6000	
	Entertainment/mobilization				2000	
Total					24100	

WASA CONNECTION (1.5" @ coil pipe)- 500 ft						
Sl no	Name of the materials	Quantity	Unit	Unit price	Amount in Taka	Remarks
1	GI Pipe @1.5"	15	rft	110	1650	
2	PVC coil Pipe @1.5"	500	rft	20	10000	
3	Earth work for Pipe lying	2400	cft	1.5	3600	
4	Clump, piece	1	nos	450	450	
5	Plumber	1	nos	800	800	
6	Short pieces				0	
7	Thread tape	8	nos	15	120	
Total					16620	

Total Material Cost	79631.94
Labour Cost	19907.98
WASA Cost	24100.00
WASA Connection	16620.00
Head carrying cost	1000.00
Message writing & ASEH marking	500.00
Grand total	141759.92

Note:

- ! All rates are followed as per present highest market price. The cost may vary depending on the present market price but should not exceed $\pm 10\%$
- ! Additional cost for road cutting permission & labour will be added where necessary.
- ! Cost could vary due to the distance from Water point to WASA service main
- ! Fencing of the Water Point is optional considering the community demand.

Estimated cost of Urban Water Point
Model no. UWP 03
Reservoir capacity 3600 liters

RESERVOIR						
Sl. No.	Name of the Item of Work/Materials	Quantity	Unit	Unit price	Amount in Taka	Remarks
1	Earthwork	348	cft		0.00	
2	Bricks	388	nos.	4.20	1629.60	
3	Filling Sand	40	cft	12.00	480.00	
4	Sand(FM 1.2 to 2.5)	71	cft	18.50	1313.50	
5	Cement	22	bag	330.00	7260.00	
6	Khoa	8	cft	45.00	360.00	
7	Manhole cover	1	nos.	900.00	900.00	
8	Ms Rod (6mm)	33	kg	45.00	1485.00	
9	MS wire mesh	1	bundle	1800.00	1800.00	
10	Shuttering/Centering	25	sft	15.00	375.00	
	Total				15603.10	

Meter Pit						
Sl. No.	Name of the Item of Work/Materials	Quantity	Unit	Unit price	Amount in Taka	Remarks
1	Earthwork	44	cft		0.00	
2	Bricks	210	nos.	4.20	882.00	
3	Filling Sand	8	cft	12.00	96.00	
4	Sand(FM 1.2 to 2.5)	12	cft	18.50	222.00	
5	Cement	3	bag	330.00	990.00	
6	Khoa	3	cft	45.00	135.00	
7	Meter pit cover -MS Sheet 14BWG	1	piece	1500.00	1500.00	
8	Lock	1	nos.	50.00	50.00	
	Total				3875.00	

Bathing/Washing Platform						
Sl. No.	Name of the Item of Work/Materials	Quantity	Unit	Unit price	Amount in Taka	Remarks
1	Earthwork	6.73	cft		0.00	
2	Bricks	394	nos.	4.20	1654.80	
3	Filling Sand	15	cft	12.00	180.00	
4	Sand(FM 1.2 to 2.5)	18	cft	18.50	333.00	
5	Cement	4	bag	330.00	1320.00	
6	Khoa	9	cft	45.00	405.00	
7	Tube well	2	Nnos.	1400.00	2800.00	
	Total				6692.80	

Plumbing						
Sl. No.	Name of the Item of Work/Materials	Quantity	Unit	Unit price	Amount in Taka	Remarks
1	G. I. Pipe (short piece)	5	rft	70.00	350.00	
2	G. I. Pipe (short piece) 1.5"	6	rft	110.00	660.00	
3	Non-return valve	1	nos.	300.00	300.00	
4	1" Gate valve	1	nos.	300.00	300.00	
5	Thread tape	5	nos.	15.00	75.00	
6	Nut	8	nos.	10.00	80.00	
7	Nipple	2	nos.	40.00	80.00	
8	Socket	6	nos.	25.00	150.00	
9	Elbow	2	nos.	25.00	50.00	
10	reducer (1"- 1.5")	2		40.00	80.00	
	Total				2125.00	

WASA						
Sl no	Name of the materials	Quantity	Unit	Unit price	Amount in Taka	Remarks
1	WASA Connection form	1		100	100	
2	WASA Dimand note	1		2500	2500	
3	WASA Security	1		1000	1000	
4	Meter & meter testing	1		4000	4000	
	Entertainment/mobilization				1000	
	Total				8600	

WASA CONNECTION (1" @ coil pipe)- 500 ft						
Sl no	Name of the materials	Quantity	Unit	Unit price	Amount in Taka	Remarks
1	GI Pipe, ft	15	rft	70	1050	
2	PVC Pipe, ft	500	rft	10	5000	
3	Earth work for Pipe lying	2400	cft	1.5	3600	
4	Clump, piece	1	nos	450	450	
5	Plumber	1	nos	800	800	
6	Short pieces		nos		0	
7	Thread tape	8	nos	15	120	
	Total				11020	

Total	Material Cost	28295.90
	Labour Cost	7073.98
	WASA Cost	8600.00
	WASA Connection	11020.00
	Head carrying cost	1000.00
	Message writing & ASEH marking	500.00
Grand total		56489.88

Note:

- ! All rates are followed as per present highest market price. The cost may vary depending on the present market price but should not exceed $\pm 10\%$
- ! Additional cost for road cutting permission & labour will be added where necessary.
- ! Cost could vary due to the distance from Water point to WASA service main
- ! Fencing of the Water Point is optional considering the community demand.

Estimated cost of Urban Water Point
Model no. UWP 04
Reservoir capacity 5000 liters

RESERVOIR						
Sl no	Name of the Item of Work/Materials	Quantity	Unit	Unit price	Amount in Taka	Remarks
1	Earthwork	431	cft		0.00	
2	Bricks	450	nos.	4.20	1890.00	
3	Filing Sand	50	cft	12.00	600.00	
4	Sand(FM 1.2 to 2.5)	85	cft	18.50	1572.50	
5	Cement	28	bag	330.00	9240.00	
6	Khoa	11	cft	45.00	495.00	
7	Manhole cover	1	nos.	900.00	900.00	
8	Ms Rod (6mm)	40	kg	45.00	1800.00	
9	MS wire mesh	1.5	bundle	1800.00	2700.00	
10	Shuttering/Centering	62	sft	15.00	930.00	
	Total				20127.50	

Meter Pit						
Sl no	Name of the Item of Work/Materials	Quantity	Unit	Unit price	Amount in Taka	Remarks
1	Earthwork	59	cft		0.00	
2	Bricks	210	nos.	4.20	882.00	
3	Filing Sand	8	cft	12.00	96.00	
4	Sand(FM 1.2 to 2.5)	13	cft	18.50	240.50	
5	Cement	3	bag	330.00	990.00	
6	Khoa	3	cft	45.00	135.00	
7	Meter pit cover -MS Sheet 14BWG	1	piece	1500.00	1500.00	
8	Lock	1	nos.	50.00	50.00	
	Total				3893.50	

Bathing/Washing Platform (6)						
Sl no	Name of the Item of Work/Materials	Quantity	Unit	Unit price	Amount in Taka	Remarks
1	Earthwork	28.82	cft		0.00	
2	Bricks	2203	nos.	4.20	9252.60	
3	Filing Sand	84.07	cft	12.00	1008.84	
4	Sand(FM 1.2 to 2.5)	110.93	cft	18.50	2052.21	
5	Cement	25	bag	330.00	8250.00	
6	Khoa	45	cft	45.00	2025.00	
7	Tube well	6	Nnos.	1400.00	8400.00	
	Total				30988.65	

Junction Box (2)						
Sl no	Name of the Item of Work/Materials	Quantity	Unit	Unit price	Amount in Taka	Remarks
1	Earthwork	33	cft		0.00	
2	Bricks	166	nos.	4.20	697.20	
3	Filing Sand	15	cft	12.00	180.00	
4	Sand(FM 1.2 to 2.5)	9	cft	18.50	166.50	
5	Cement	2	bag	330.00	660.00	
6	Khoa	4	cft	45.00	180.00	
7	MS Sheet 14BWG	2	Piece	1000.00	2000.00	
	Total				3883.70	

Plumbing						
Sl no	Name of the Item of Work/Materials	Quantity	Unit	Unit price	Amount in Taka	Remarks
1	G. I. Pipe short pice 1.5"@	30	rft	110.00	3300.00	
2	G. I. Pipe 1.5"@	18	rft	110.00	1980.00	
3	Non-return valve 1.5"	1	rft	800.00	800.00	
4	check valve 1"	6	nos.	700.00	4200.00	
5	1" Gate valve	6	nos.	300.00	1800.00	
6	1" pvc coil pipe	300	rft	10.00	3000.00	
7	Thread tape	10	nos.	15.00	150.00	
8	Nut	40	nos.	10.00	400.00	
9	Nipple	8	nos.	40.00	320.00	
10	Socket	8	nos.	30.00	240.00	
11	Elbow	12	nos.	35.00	420.00	
12	Reducer (1.5"-1")	6	nos.	50.00	300.00	
Total					16910.00	

WASA (1.5" @ connection)						
Sl no	Name of the materials	Quantity	Unit	Unit price	Amount in Taka	Remarks
1	WASA Connection form	1		100	100	
2	WASA Dimand note	1		14000	14000	
3	WASA Security			2000	2000	
4	Meter & meter testing	1		6000	6000	
	Entertainment/mobilization				2000	
Total					24100	

WASA CONNECTION (1" @ coil pipe)- 500 ft						
Sl no	Name of the materials	Quantity	Unit	Unit price	Amount in Taka	Remarks
1	GI Pipe @1.5"	15	rft	110	1650	
2	PVC coil Pipe @1.5"	500	rft	20	10000	
3	Earth work for Pipe lying	2400	cft	1.5	3600	
4	Clump, piece	1		450	450	
5	Plumber	1		800	800	
6	Short pieces				0	
7	Thread tape	8		15	120	
Total					16620	

Total Material Cost	75803.35
Labour Cost	18950.84
WASA Cost	24100.00
WASA Connection	16620.00
Head carrying cost	1000.00
Message writing & ASEH marking	500.00
Grand total	136974.18

Note:

- ! All rates are followed as per present highest market price. The cost may vary depending on the present market price but should not exceed $\pm 10\%$
- ! Additional cost for road cutting permission & labour will be added where necessary.
- ! Cost could vary due to the distance from Water point to WASA service main
- ! Fencing of the Water Point is optional considering the community demand.

Estimated cost of Urban Water Point
Model no. UWP 05
Reservoir capacity 2200 liters

RESERVOIR						
Sl no	Name of the Item of Work/Materials	Quantity	Unit	Unit price	Amount in Taka	Remarks
1	Earthwork	287	cft	0.00	0.00	
2	Bricks	1059	nos.	4.20	4447.80	
3	Filing Sand	42	cft	12.00	504.00	
4	Sand(FM 1.2 to 2.5)	61	cft	18.50	1128.50	
5	Cement	15	bag	330.00	4950.00	
6	Khoa	35	cft	45.00	1575.00	
7	Manhole cover	1	nos.	900.00	900.00	
8	MS Rod (#3 deformed bar)	75	kg	45.00	3375.00	
9	Shuttering/Centering	51	sft	15.00	765.00	
	Total				17645.30	

Meter Pit						
Sl no	Name of the Item of Work/Materials	Quantity	Unit	Unit price	Amount in Taka	Remarks
1	Earthwork	38.3	cft		0.00	
2	Bricks	125	nos.	4.20	525.00	
3	Filing Sand	6.21	cft	12.00	74.52	
4	Sand(FM 1.2 to 2.5)	8.79	cft	18.50	162.62	
5	Cement	2	bag	330.00	660.00	
6	Khoa	2	cft	45.00	90.00	
7	Meter pit cover -MS Sheet 14BWG	1	piece	1500.00	1500.00	
8	Lock	1		50.00	50.00	
	Total				3062.14	

Bathing/Washing Platform						
Sl no	Name of the Item of Work/Materials	Quantity	Unit	Unit price	Amount in Taka	Remarks
1	Earthwork	5	cft		0.00	
2	Bricks	292	nos.	4.20	1226.40	
3	Filing Sand	12	cft	12.00	144.00	
4	Sand(FM 1.2 to 2.5)	13	cft	18.50	240.50	
5	Cement	3	bag	330.00	990.00	
6	Khoa	2	cft	40.00	80.00	
7	Tube well	2	nos.	1400.00	2800.00	
	Total				5480.90	

Plumbing						
Sl no	Name of the Item of Work/Materials	Quantity	Unit	Unit price	Amount in Taka	Remarks
1	G. I. Pipe (short piece)	5	rft	70.00	350.00	
2	G. I. Pipe (short piece) 1.5"	6	rft	110.00	660.00	
3	Non-return valve	1	nos.	300.00	300.00	
4	1" Gate valve	1	nos.	300.00	300.00	
5	Thread tape	5	nos.	15.00	75.00	
6	Nut	8	nos.	10.00	80.00	
7	Nipple	2	nos.	40.00	80.00	
8	Socket	6	nos.	30.00	180.00	
9	Elbow	2	nos.	35.00	70.00	
10	reducer (1"- 1.5")	2		50.00	100.00	
	Total				2195.00	

WASA						
Sl no	Name of the materials	Quantity	Unit	Unit price	Amount in Taka	Remarks
1	WASA Connection form	1		100	100	
2	WASA Dimand note	1		2500	2500	
3	WASA Security	1		1000	1000	
4	Meter & meter testing	1		4000	4000	
	Entertainment/mobilization				1000	
	Total				8600	

WASA CONNECTION (1" @ coil pipe)- 500 ft						
Sl no	Name of the materials	Quantity	Unit	Unit price	Amount in Taka	Remarks
1	GI Pipe, ft	15	rft	70	1050	
2	PVC Pipe, ft	500	rft	10	5000	
3	Earth work for Pipe lying	2400	cft	1.5	3600	
4	Clump, piece	1	nos	450	450	
5	Plumber	1	nos	800	800	
6	Short pieces	0	nos		0	
7	Thread tape	8	nos	15	120	
	Total				11020	

Total Material Cost	28383.34
Labour Cost	7095.83
WASA Cost	8600.00
WASA Connection	11020.00
Head carrying cost	1000.00
ASEH marking	500.00
Grand total	56599.17

Note:

- ‡ All rates are followed as per present highest market price. The cost may vary depending on the present market price but should not exceed $\pm 10\%$
- ‡ Additional cost for road cutting permission & labour will be added where necessary.
- ‡ Cost could vary due to the distance from Water point to WASA service main
- ‡ Fencing of the Water Point is optional considering the community demand.

Estimated cost of Urban Stand Post

Model no. USP

Meter Pit						
Sl no	Name of the Item of Work/Materials	Quantity	Unit	Unit price	Amount in Taka	Remarks
1	Earthwork	46	cft	0.00	0.00	
2	Bricks	159	nos.	4.20	667.80	
3	Filing Sand	10	cft	12.00	120.00	
4	Sand(FM 1.2 to 2.5)	10	cft	18.50	185.00	
5	Cement	2	bag	330.00	660.00	
6	Khoa	3	cft	45.00	135.00	
7	Meter pit cover -MS Sheet 14BWG	1	piece	1500.00	1500.00	
8	Lock	1	nos.	50.00	50.00	
	Total				3317.80	

Bathing/Washing Platform						
Sl no	Name of the Item of Work/Materials	Quantity	Unit	Unit price	Amount in Taka	Remarks
1	Earthwork	3	cft	0.00	0.00	
2	Bricks	358	nos.	4.20	1503.60	
3	Filing Sand	14	cft	14.00	196.00	
4	Sand(FM 1.2 to 2.5)	17	cft	18.50	314.50	
5	Cement	4	bag	330.00	1320.00	
6	Khoa	9	cft	45.00	405.00	
7	Tap	1	Nos.	200.00	200.00	
	Total				3939.10	

Plumbing						
Sl no	Name of the Item of Work/Materials	Quantity	Unit	Unit price	Amount in Taka	Remarks
1	G. I. Pipe	6	rft	70.00	420.00	
2	Non-return valve	0	rft	300.00	0.00	
3	1" Gate valve	1	nos.	300.00	300.00	
4	Thread tape	2	nos.	15.00	30.00	
5	Nut	0	nos.	10.00	0.00	
6	Nipple	2	nos.	40.00	80.00	
7	Socket	2	nos.	35.00	70.00	
8	Elbow	2	nos.	40.00	80.00	
9	Reducer (1.5" - 1")	0	nos.	40.00	0.00	
	Total				980.00	

WASA						
Sl no	Name of the materials	Quantity	Unit	Unit price	Amount in Taka	Remarks
1	WASA Connection form	1		100	100	
2	WASA Dimand note	1		2500	2500	
3	WASA Security	1		1000	1000	
4	Meter	1		4000	4000	
	Entertainment/mobilization				1000	
5	Total				8600	

WASA CONNECTION (1" @ coil pipe)- 500 ft						
Sl no	Name of the materials	Quantity	Unit	Unit price	Amount in Taka	Remarks
1	GI Pipe, ft	15	ft	70	1050	
2	PVC Pipe, ft	500	ft	10	5000	
3	Earth work for Pipe lying	2400	cft	1.5	3600	
4	Clump, piece	1	nos	450	450	
5	Plumber	1	nos	800	800	
6	Short pieces				0	
7	Thread tape	8	nos	15	120	
	Total				11020	

Total Material Cost	8236.90
Labour Cost	2059.23
WASA Cost	8600.00
WASA Connection	11020.00
Head carrying cost	1000.00
Message writing & ASEH marking	500.00
Grand total	31416.13

Note:

- ! All rates are followed as per present highest market price. The cost may vary depending on the present market price but should not exceed $\pm 10\%$
- ! Additional cost for road cutting permission & labour will be added where necessary.
- ! Cost could vary due to the distance from Water point to WASA service main
- ! Fencing of the Water Point is optional considering the community demand.